

Omnia L

THE BEST OPTION
ON THE MARKET

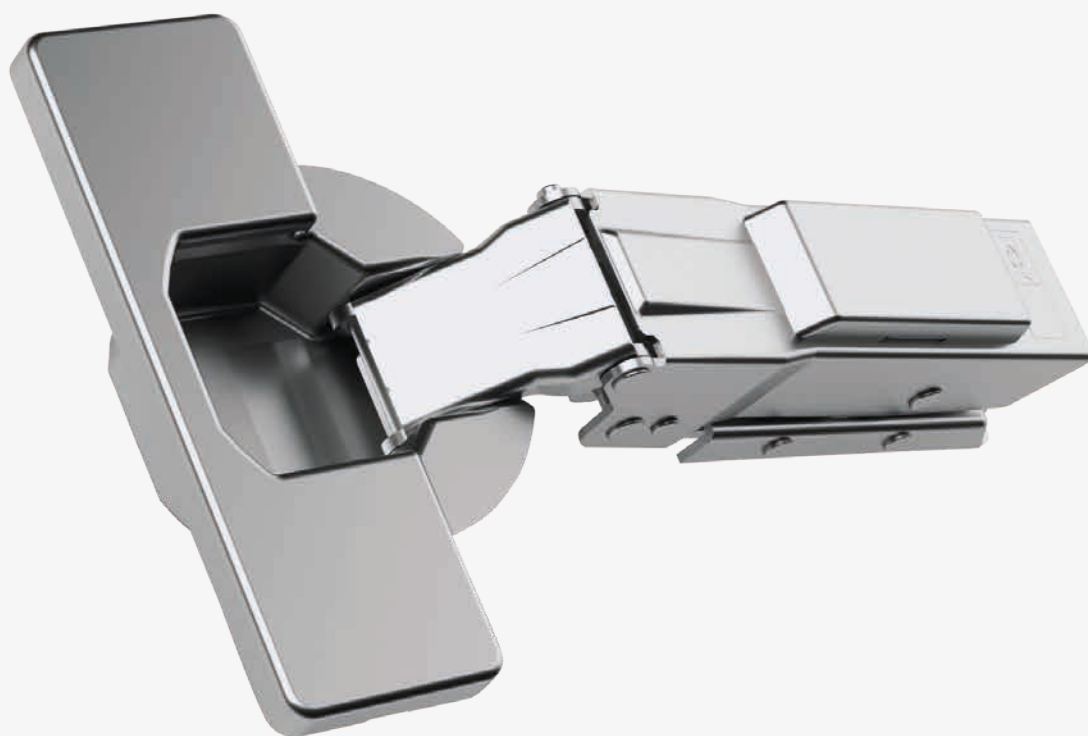
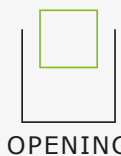

FORMENTI & GIOVENZANA
PROVIDES FUNCTIONAL
SOLUTIONS FOR FURNITURE TO
MEET THE REAL NEEDS OF A
LARGE NUMBER OF CUSTOMERS.

All products are conceived and supplied with care and quality and are offered to the market at a competitive price. In this way, Formenti & Giovenzana contributes globally to increase the satisfaction of the customers buying furniture, giving access to pleasing features and improving the quality of life of the consumers.

Content

- 02 - INTRO
- 04 - REASONS TO CHOOSE OMNIA L
- 06 - OMNIA L
- 08 - OMNIA L 105°
- 10 - OMNIA L 105° FOR CORNER DOORS
- 12 - OMNIA L 155°
- 14 - OMNIA L FOR CORNER CABINET 90°
- 16 - OMNIA L 105° FOR DOORS WITH ALUMINIUM FRAME
- 18 - ACCESSORIES

Omnia L

SLOWMOTION TECHNOLOGY INSIDE
IMPROVED MODERN DESIGN
STRENGTH AND HIGH
PERFORMANCES
EASY CLICK FIXING SYSTEM

The Omnia L hinge, from old latin language: omnia, omnium. represents the perfect synthesis of all the best features.

All the best as concern the technical know-how.
All the must-have features for a premium hinge.
All the FGV experience developed in 70 years on the Market.

All that a Customer can get from an hinge.
Omnia L is really the best option on the market!

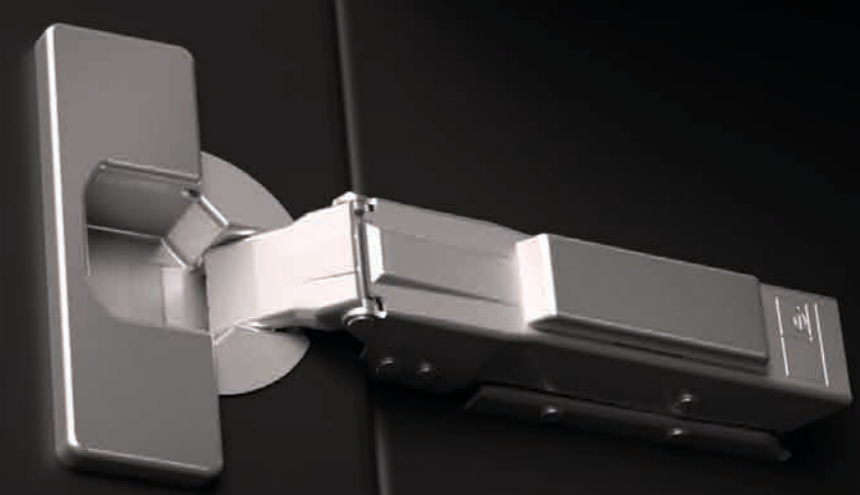

Reasons to choose Omnia L

OMNIA L HINGE RANGE

The Omnia L SlowMotion hinge is the new top product of the FGV's offer originates from the research and the experience built up in over 70 years of presence in the field. Equipped with a state-of-the-art Linear SlowMotion Technology, it ensures stable and constant operation in all conditions of use. Produced in Italy it boosts all the best features and performances required by the market of damped systems.

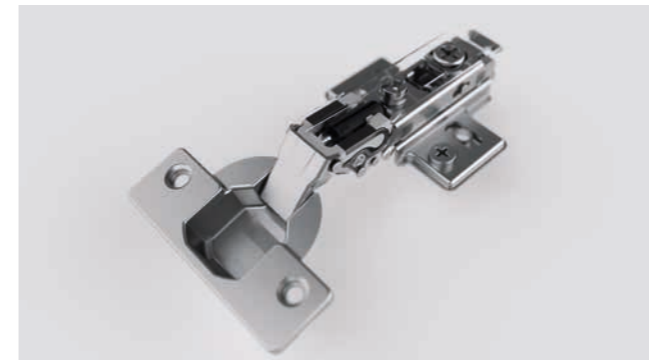
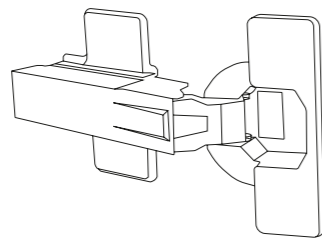

ALL THE BENEFITS FROM THE LINEAR SLOWMOTION

State-of-the-art Linear SlowMotion Technology, for a perfect damped closure in every condition, based on stable shock absorber at all high and low temperatures, adaptive controlled movement without manual adjustments, 25° of smooth braking to avoid door rebound.

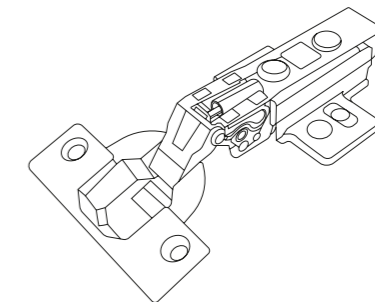

NEVER SO EASY TO HANG A DOOR!

No limits to door dimensions and to hinge numbers. AnyClickSystem an intelligent and practical solution to fit the hinges in any position without any stress. A really fantastic simplification for the wardrobe doors.

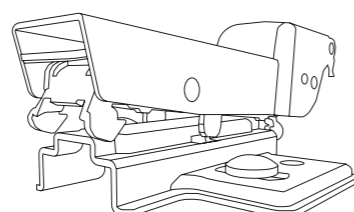

A TECHNOLOGY TO COVER EVERY APPLICATION

Full range of cranks and angle solutions; full choice of fixing systems, included the Velofix version. Range of reversible mounting plates with 3D independent adjustment: fast, simple, precise and intuitive.

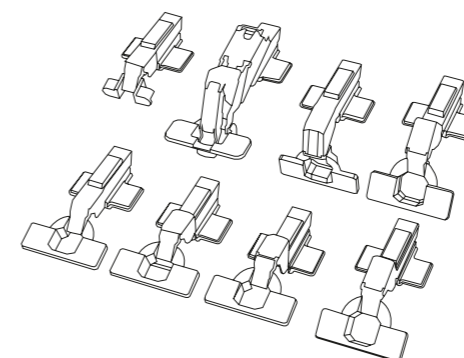

Omnia L

PERFORMANCE

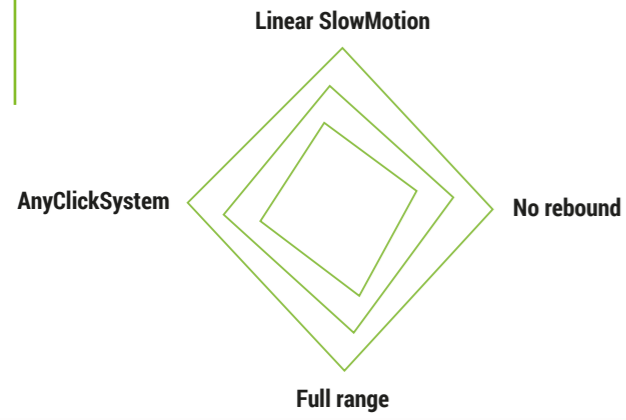

Linear SlowMotion Damper hidden into the hinge arm

Linear Mounting Plate

Modern and elegant design patented

Box and Arm cover caps

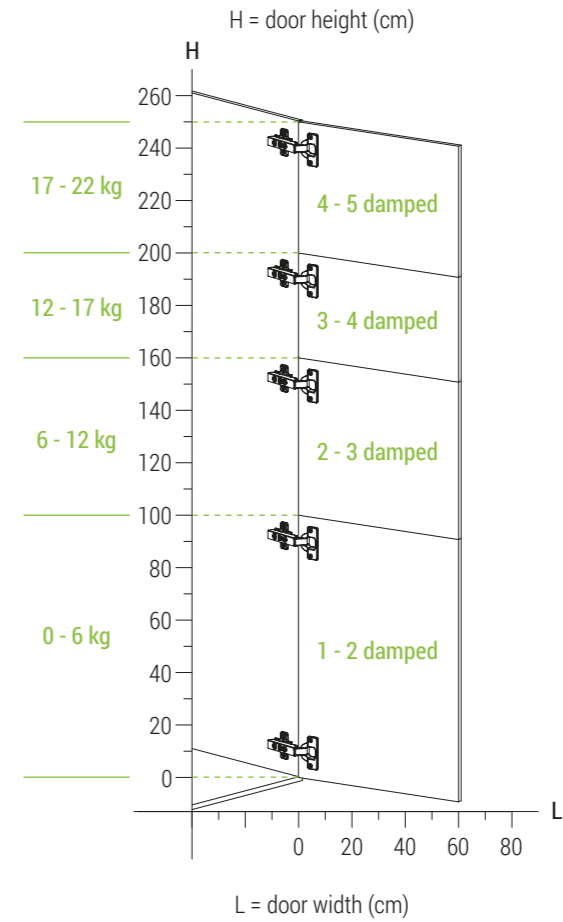
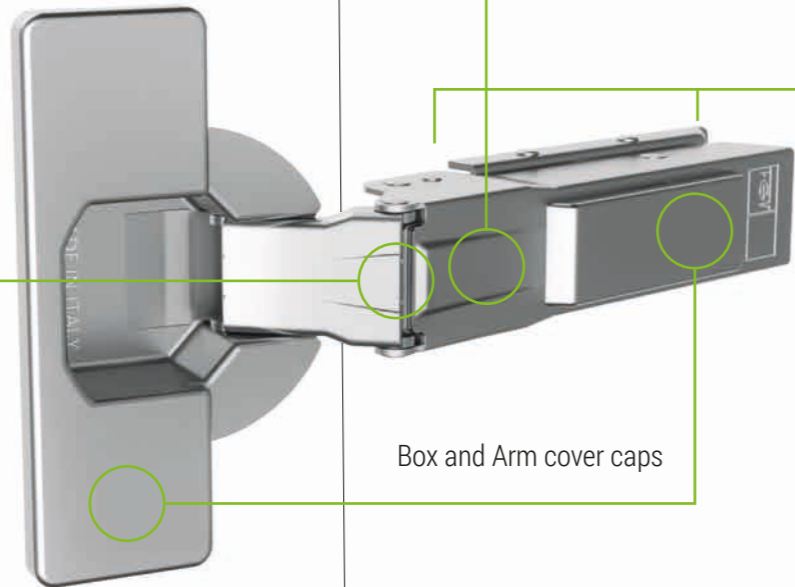

ANYCLICKSYSTEM

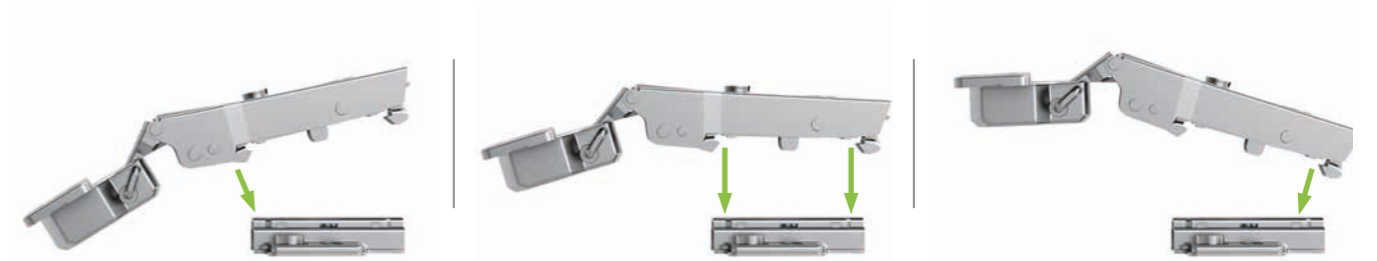

For an easy and quick fitting in any position.

ADJUSTING SYSTEM



Depth adjustment
Acting on the "A" screw it is possible to adjust the distance between the side of the cabinet and the door.

Independent side adjustment
Acting on the "B" screw it is possible to change the amount of the door covering on the side of the cabinet.

Vertical adjustment
Acting on the "C" screw of the mounting plate it is possible to adjust the door vertically.



Technical Specifications:

- Depth of the metal cup 11.4 mm
- Cup diameter 35 mm
- Opening 105°
- Possibility of door drilling (K) from 3 to 7 mm
- Thickness of the door (T) from 14 to 26 mm
- Available with cup hole distance I.48, A.45, D.52
- Complete program of fixing systems with Selftapping and Euro screw; Expando, EasyFix and knock-in Dowel

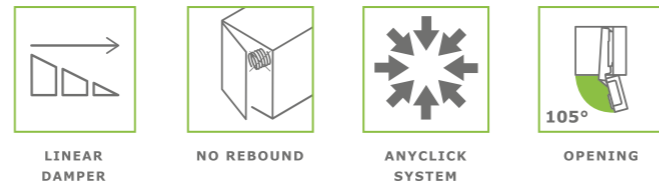

CRANK 0



CRANK 8



CRANK 15



I48
A45
D52

51.LSW0.M9.00.IX000	51.LSW0.M9.08.IX000	51.LSW0.M9.15.IX000
51.LSW0.M9.00.AX000	51.LSW0.M9.08.AX000	51.LSW0.M9.15.AX000
51.LSW0.M9.00.DX000	51.LSW0.M9.08.DX000	51.LSW0.M9.15.DX000

Available also with premounted selftapping screw (sample code 51.LSWP.M9.00.IX000)



I48
A45
D52

51.LSEP.M9.00.IX000	51.LSEP.M9.08.IX000	51.LSEP.M9.15.IX000
51.LSEP.M9.00.AX000	51.LSEP.M9.08.AX000	51.LSEP.M9.15.AX000
51.LSEP.M9.00.DX000	51.LSEP.M9.08.DX000	51.LSEP.M9.15.DX000

Available also without euro screw (sample code 51.LSE0.M9.00.IX000)

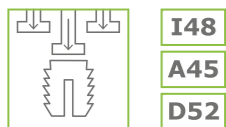

I48
A45
D52

51.LSD0.M9.00.IX000	51.LSD0.M9.08.IX000	51.LSD0.M9.15.IX000
51.LSD8.M9.00.AX000	51.LSD8.M9.08.AX000	51.LSD8.M9.15.AX000
51.LSD0.M9.00.DX000	51.LSD0.M9.08.DX000	51.LSD0.M9.15.DX000

D0 = dowels Ø10 / D8 = dowels Ø8



I48
A45
D52

51.LSV0.M9.00.IX000	51.LSV0.M9.08.IX000	51.LSV0.M9.15.IX000
51.LSV8.M9.00.AX000	51.LSV8.M9.08.AX000	51.LSV8.M9.15.AX000
51.LSV0.M9.00.DX000	51.LSV0.M9.08.DX000	51.LSV0.M9.15.DX000

V0 = dowels Ø10mm / V8 = dowels Ø8mm



I48
A45
D52

51.LSX0.M9.00.IX000	51.LSX0.M9.08.IX000	51.LSX0.M9.15.IX000
51.LSX8.M9.00.AX000	51.LSX8.M9.08.AX000	51.LSX8.M9.15.AX000
51.LSX0.M9.00.DX000	51.LSX0.M9.08.DX000	51.LSX0.M9.15.DX000

X0 = dowels Ø10mm / X8 = dowels Ø8mm

For mounting plates and fittings see pages 18 - 25.

Versions not damped available for all applications in the above table (sample code 51.LSW0.M9.00.I0000)

CRANK 0 For lay-on doors

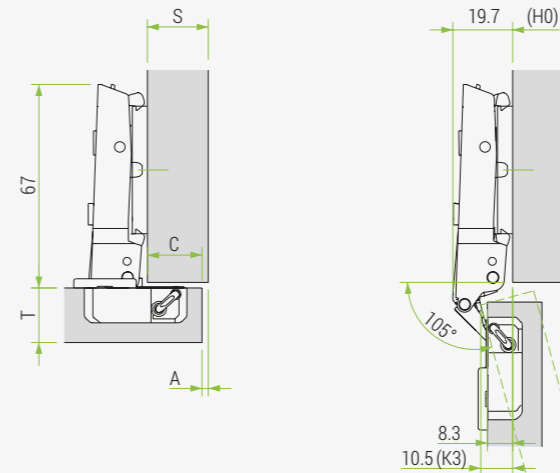

H*	Drilling distance (k)					
	3	4	5	6	7	
Overlay (C) Crank 0	19			0		
	18			0	2	
	17		0		2	
	16	0		2		4
	15		2		4	
	14	2		4		6
	13		4		6	
	12	4		6		
	11		6			
10	6					

* = with H between two values get the lower one

CRANK 8 For partial lay-on doors

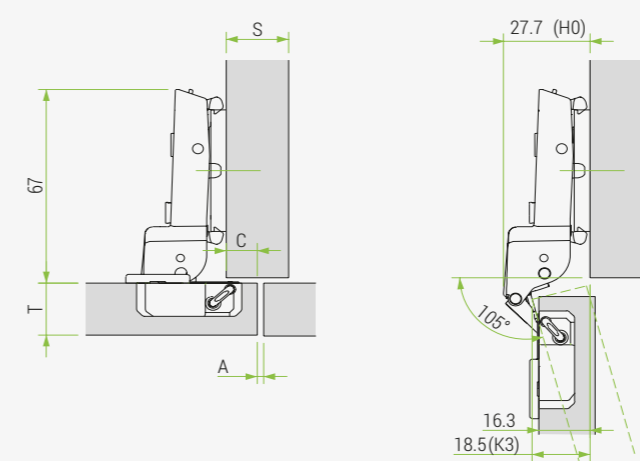

H*	Drilling distance (k)					
	3	4	5	6	7	
Overlay (C) Crank 8	11			0		
	10			0	2	
	9		0		2	
	8	0		2		4
	7		2		4	
	6	2		4		6
	5		4		6	
	4	4		6		
	3		6			
	2	6				

* = with H between two values get the lower one

CRANK 15 For inset doors

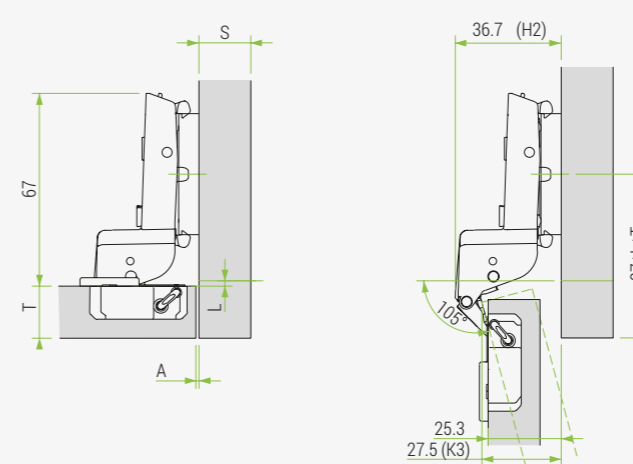

H*	Drilling distance (k)					
	3	4	5	6	7	
Overlay (C) Crank 15	1	0		2		4
	0			2		4
	-1	2		4		6
	-2		4		6	
	-3	4		6		
	-4		6			
	-5					
	-6					
	-7					
-8						

* = with H between two values get the lower one

Table to determinate the minimum distance A so that a door with T thickness can open without protrusion from the cabinet and without interfering with adjacent doors.

T=	14	15	16	17	18	19	20	21	22	23	24	25	26
K=3	A= 0.1	0.2	0.3	0.4	0.5	0.7	0.8	1	1.2	2	3.2	4.5	5.8
K=4	A= 0.1	0.2	0.3	0.4	0.5	0.6	0.8	1	1.2	1.4	2.2	3.5	4.9
K=5	A= 0.1	0.2	0.3	0.3	0.5	0.6	0.8	1	1.2	1.4	1.6	2.5	3.8
K=6	A= 0.1	0.2	0.3	0.3	0.5	0.6	0.8	1	1.2	1.4	1.6	1.9	2.8
K=7	A= 0.1	0.2	0.3	0.3	0.5	0.6	0.8	1	1.2	1.4	1.6	1.9	2.8



Technical Specifications:

- Depth of the metal cup 11.4 mm
- Cup diameter 35 mm
- Opening 105°
- Possibility of door drilling (K) from 3 to 7 mm
- Thickness of the door (T) from 14 to 26 mm
- Available with cup hole distance I.48, A.45, D.52
- Complete program of fixing systems with Selftapping and Euro screw; Expando, EasyFix and knock-in Dowel

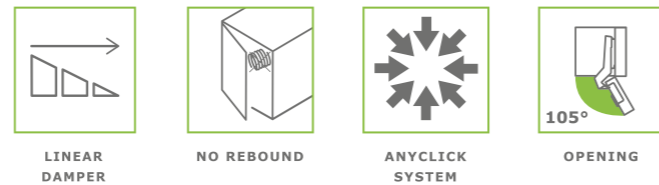

ANGLE 24° / 30°



ANGLE 45°



ANGLE 90°



I48
A45
D52

51.LSW0.M9.30.IX000
51.LSW0.M9.30.AX000
51.LSW0.M9.30.DX000

51.LSW0.M9.45.IX000
51.LSW0.M9.45.AX000
51.LSW0.M9.45.DX000

51.LSW0.M9.90.IX000
51.LSW0.M9.90.AX000
51.LSW0.M9.90.DX000

Available also with premounted selftapping screw (sample code 51.LSWP.M9.30.IX000)



I48
A45
D52

51.LSEPM9.30.IX000
51.LSEPM9.30.AX000
51.LSEPM9.30.DX000

51.LSEPM9.45.IX000
51.LSEPM9.45.AX000
51.LSEPM9.45.DX000

51.LSEPM9.90.IX000
51.LSEPM9.90.AX000
51.LSEPM9.90.DX000

Available also without euro screw (sample code 51.LSE0.M9.30.IX000)

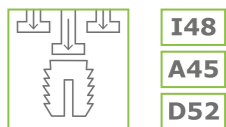

I48
A45
D52

51.LSD0.M9.30.IX000
51.LSD8.M9.30.AX000
51.LSD0.M9.30.DX000

51.LSD0.M9.45.IX000
51.LSD8.M9.45.AX000
51.LSD0.M9.45.DX000

51.LSD0.M9.90.IX000
51.LSD8.M9.90.AX000
51.LSD0.M9.90.DX000

D0 = dowels Ø10 / D8 = dowels Ø8



I48
A45
D52

51.LSV0.M9.30.IX000
51.LSV8.M9.30.AX000
51.LSV0.M9.30.DX000

51.LSV0.M9.45.IX000
51.LSV8.M9.45.AX000
51.LSV0.M9.45.DX000

51.LSV0.M9.90.IX000
51.LSV8.M9.90.AX000
51.LSV0.M9.90.DX000

V0 = dowels Ø10mm / V8 = dowels Ø8mm



I48
A45
D52

51.LSX0.M9.30.IX000
51.LSX8.M9.30.AX000
51.LSX0.M9.30.DX000

51.LSX0.M9.45.IX000
51.LSX8.M9.45.AX000
51.LSX0.M9.45.DX000

51.LSX0.M9.90.IX000
51.LSX8.M9.90.AX000
51.LSX0.M9.90.DX000

X0 = dowels Ø10mm / X8 = dowels Ø8mm

Versions not damped available for all applications in the above table (sample code 51.LSW0.M9.30.I0000)

For mounting plates and fittings see pages 18 - 25.

ANGLE 24° / 30°

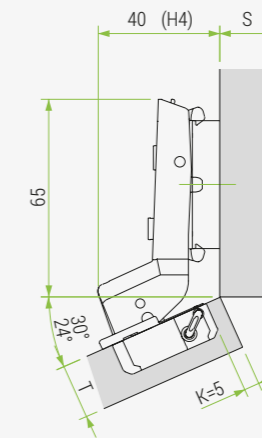

ANGLE 45°

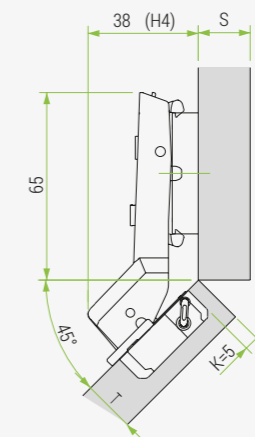

ANGLE 90°

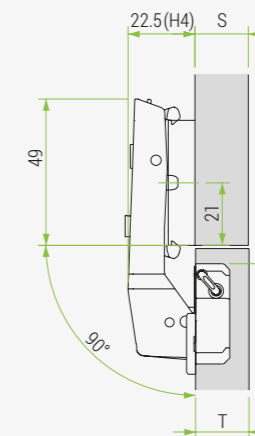
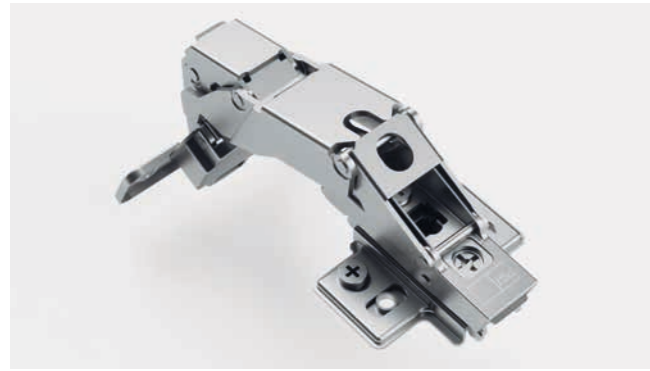

Table to determinate the minimum distance A so that a door with T thickness can open without protrusion from the cabinet and without interfering with adjacent doors.

T=	14	15	16	17	18	19	20	21	22	23	24	25	26
K=3	A= 0.1	0.2	0.3	0.4	0.5	0.7	0.8	1	1.2	2	3.2	4.5	5.8
K=4	A= 0.1	0.2	0.3	0.4	0.5	0.6	0.8	1	1.2	1.4	2.2	3.5	4.9
K=5	A= 0.1	0.2	0.3	0.3	0.5	0.6	0.8	1	1.2	1.4	1.6	2.5	3.8
K=6	A= 0.1	0.2	0.3	0.3	0.5	0.6	0.8	1	1.2	1.4	1.6	1.9	2.8
K=7	A= 0.1	0.2	0.3	0.3	0.5	0.6	0.8	1	1.2	1.4	1.6	1.9	2.8



Technical Specifications:

- Depth of the metal cup 11.3 mm
- Cup diameter 35 mm
- Opening 155°
- Possibility of door drilling (K) from 3 to 7 mm
- Thickness of the door (T) from 14 to 26 mm
- Available with cup hole distance I.48, A.45, D.52
- Complete program of fixing systems with Selftapping and Euro screw; EasyFix and knock-in Dowel

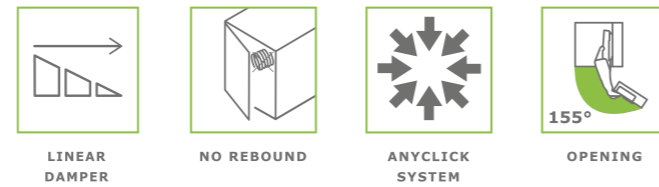

CRANK 0



CRANK 8



I48
A45
D52

51.LWW0.M9.00.IX000
51.LWW0.M9.00.AX000
51.LWW0.M9.00.DX000

51.LWW0.M9.08.IX000
51.LWW0.M9.08.AX000
51.LWW0.M9.08.DX000

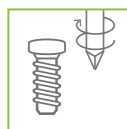

I48
A45
D52

51.LWEP.M9.00.IX000
51.LWEP.M9.00.AX000
51.LWEP.M9.00.DX000

51.LWEP.M9.08.IX000
51.LWEP.M9.08.AX000
51.LWEP.M9.08.DX000

Available also without euro screw (sample code 51.LWE0.M9.00.IX000)

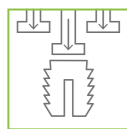

I48
A45
D52

51.LWD0.M9.00.IX000
51.LWD8.M9.00.AX000
51.LWD0.M9.00.DX000

51.LWD0.M9.08.IX000
51.LWD8.M9.08.AX000
51.LWD0.M9.08.DX000

D0 = dowels Ø10 / D8 = dowels Ø8

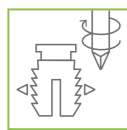

I48
A45
D52

51.LWV0.M9.00.IX000
51.LWV8.M9.00.AX000
51.LWV0.M9.00.DX000

51.LWV0.M9.08.IX000
51.LWV8.M9.08.AX000
51.LWV0.M9.08.DX000

V0 = dowels Ø10mm / V8 = dowels Ø8mm

For mounting plates and fittings see pages 18 - 25.

Versions not damped available for all applications in the above table (sample code 51.LWW0.M9.00.I0000)

CRANK 0 For lay-on doors

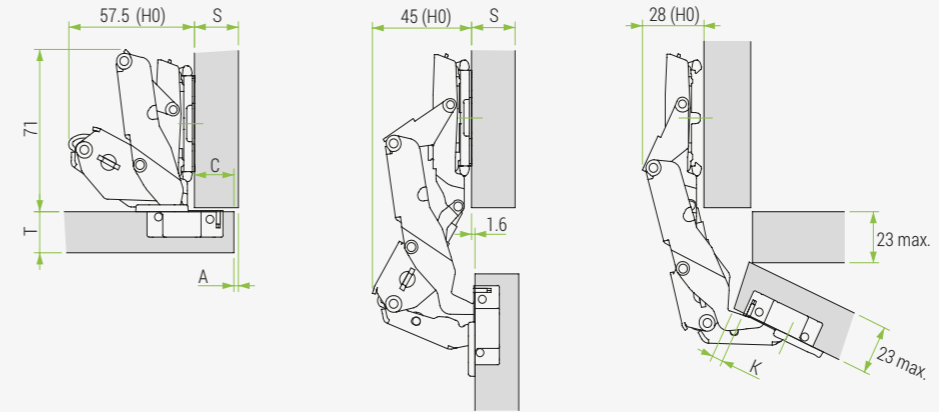

H*	Drilling distance (k)				
	3	4	5	6	7
19				0	
18			0		2
17		0		2	
16	0		2		4
15		2		4	
14	2		4		6
13		4		6	
12	4		6		
11		6			
10	6				

* = with H between two values get the lower one

CRANK 8 For partial lay-on doors

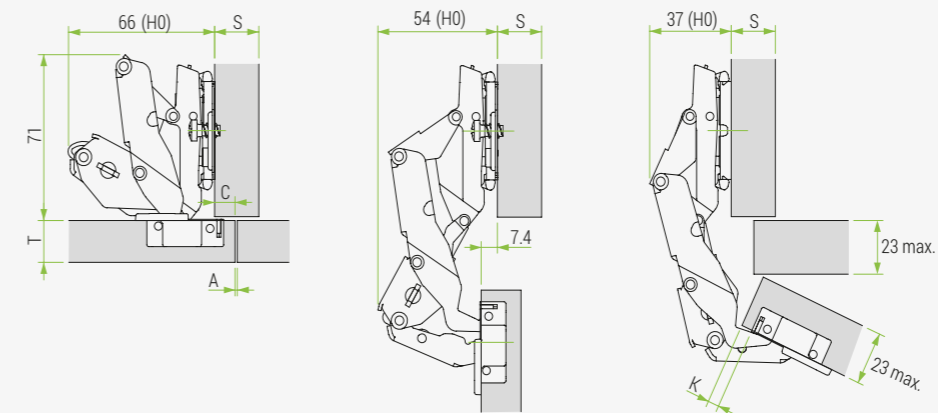

H*	Drilling distance (k)				
	3	4	5	6	7
11				0	
10			0		2
9		0		2	
8	0		2		4
7		2		4	
6	2		4		6
5		4		6	
4	4		6		
3		6			
2	6				

* = with H between two values get the lower one

Table to determinate the minimum distance A so that a door with T thickness can open without protrusion from the cabinet and without interfering with adjacent doors.

T=	14	15	16	17	18	19	20	21	22	23	24	25	26
K=3 A=	0	0	0	0	0	0	0	0	0	0	0	13.7	18
K=4 A=	0	0	0	0	0	0	0	0	0	0	0	12.7	17
K=5 A=	0	0	0	0	0	0	0	0	0	0	7.4	11.7	16
K=6 A=	0	0	0	0	0	0	0	0	0	0	6.4	10.7	15
K=7 A=	0	0	0	0	0	0	0	0	0	0	5.4	9.7	14



Technical Specifications:

- Depth of the metal cup 11.4 mm
- Cup diameter 35 mm
- Opening 50°
- Possibility of door drilling (K) from 3 to 7 mm
- Thickness of the door (T) from 14 to 26 mm
- Available with cup hole distance I.48, A.45, D.52
- Complete program of fixing systems with Selftapping and Euro screw; Expando, EasyFix and knock-in Dowel



I48
A45
D52

51.LPW0.M9.00.I0000
51.LPW0.M9.00.A0000
51.LPW0.M9.00.D0000

Available also with premounted selftapping screw (sample code 51.LPWP.M9.00.I0000)

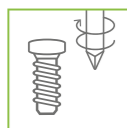

I48
A45
D52

51.LPEP.M9.00.I0000
51.LPEP.M9.00.A0000
51.LPEP.M9.00.D0000

Available also without euro screw (sample code 51.LPE0.M9.00.I0000)

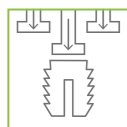

I48
A45
D52

51.LPD0.M9.00.I0000
51.LPD8.M9.00.A0000
51.LPD0.M9.00.D0000

D0 = dowels Ø10 / D8 = dowels Ø8

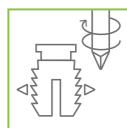

I48
A45
D52

51.LPV0.M9.00.I0000
51.LPV8.M9.00.A0000
51.LPV0.M9.00.D0000

V0 = dowels Ø10mm / V8 = dowels Ø8mm

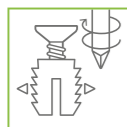

I48
A45
D52

51.LPX0.M9.00.I0000
51.LPX8.M9.00.A0000
51.LPX0.M9.00.D0000

X0 = dowels Ø10mm / X8 = dowels Ø8mm

For mounting plates and fittings see pages 18 - 25.

For all applications in the above table available only versions not damped

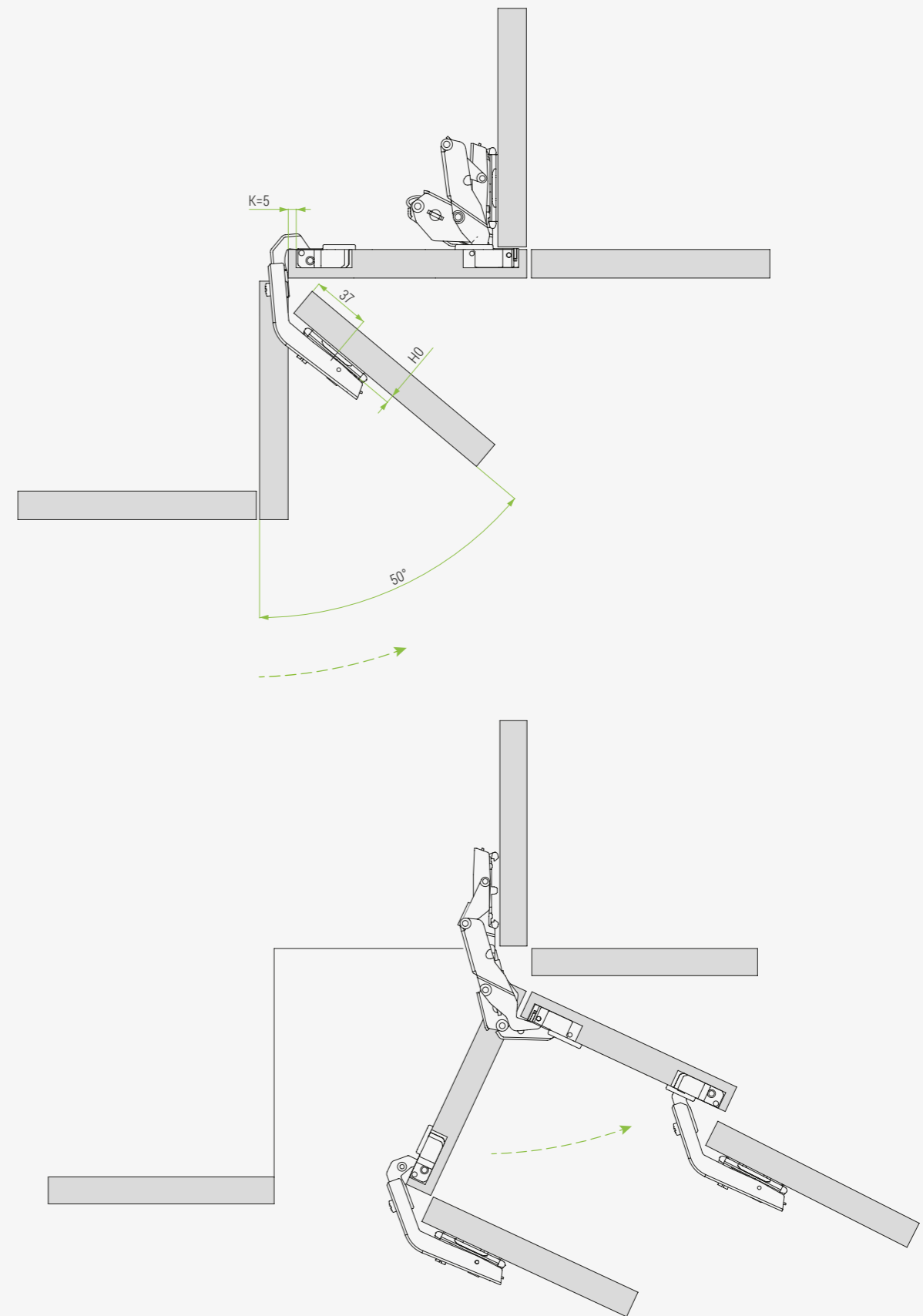



Technical Specifications:

- Depth of the zamak cup 9.9 mm
- Cup drilling 28x7 mm
- Opening 105°
- Aluminium frame from min. 19 to max 26 mm
- Available with cup hole distance I.48, A.45, D.52
- Complete program of fixing systems with Selftapping and Euro screw; Expando, EasyFix and knock-in Dowel

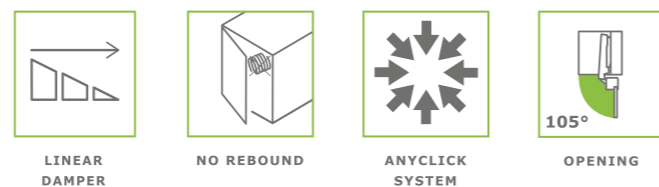

CRANK 0



51.LSA0.M9.00.0X000

CRANK 8



51.LSA0.M9.08.0X000

CRANK 15



51.LSA0.M9.15.0X000

Versions not damped available for all applications in the above table (sample code 51.LSA0.M9.00.00000)

Drilling holes

The two laterals drillings are Ø4 mm and are countersunk with 120°. Screws Ø3.5x12 mm supplied on demand under code 1A05512105000.

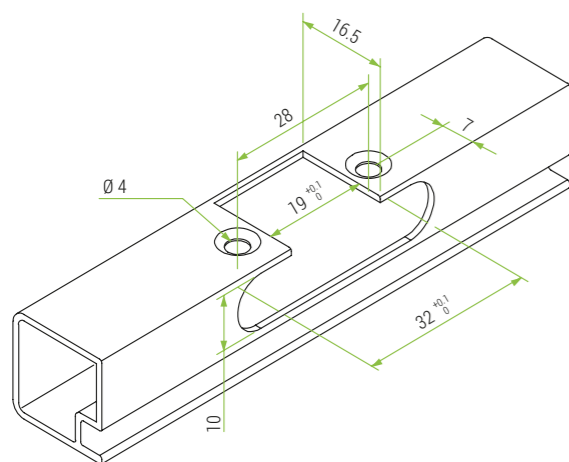

Assembly instructions

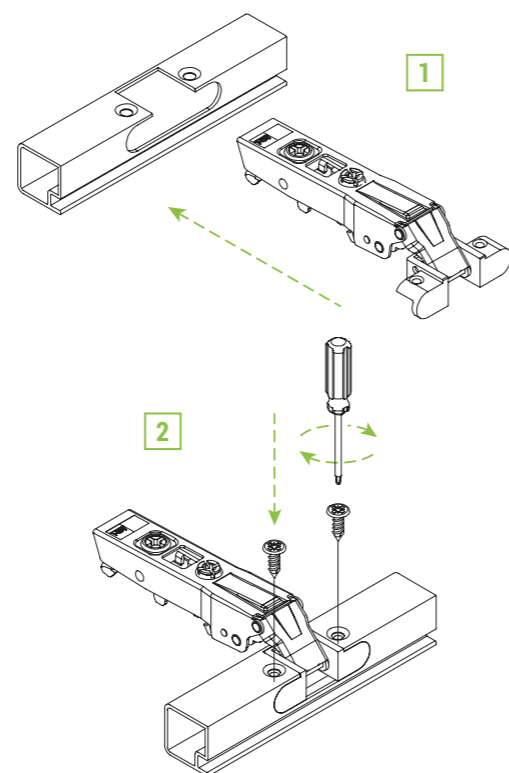

CRANK 0 For lay-on doors

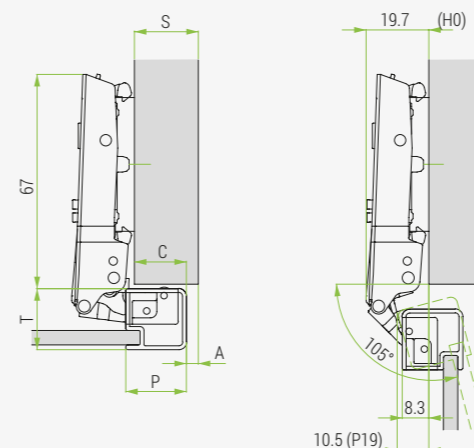

H*	Profile height (P)			
	19			
Overlay (C) Crank 0	16	0		
	15			
	14	2		
	13			
	12	4		
	11			
10	6			

* = with H between two values get the lower one

CRANK 8 For partial lay-on doors

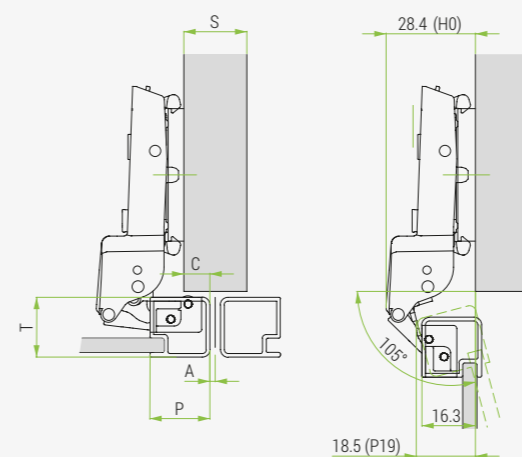

H*	Profile height (P)			
	19			
Overlay (C) Crank 8	8	0		
	7			
	6	2		
	5			
	4	4		
	3			
2	6			

* = with H between two values get the lower one

CRANK 15 For inset doors

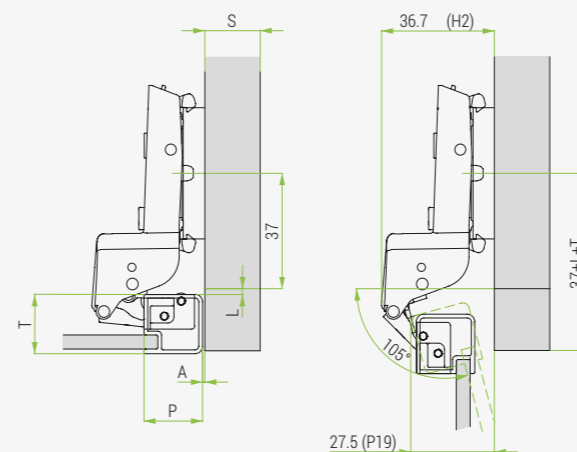

H*	Profile height (P)			
	19			
Overlay (C) Crank 8	1	0		
	0			
	-1	2		
	-2			
	-3	4		
	-4			
-5	6			

* = with H between two values get the lower one

Table to determinate the minimum distance A so that a door with T thickness can open without protrusion from the cabinet and without interfering with adjacent doors.

T=	19	20	21	22	23	24	25	26
P=19 A=	0.7	0.8	1	1.2	2	3.2	4.5	5.8
P=20 A=	0.6	0.8	1	1.2	1.4	2.2	3.5	4.9
P=21 A=	0.6	0.8	1	1.2	1.4	1.6	2.5	3.8
P=22 A=	0.6	0.8	1	1.2	1.4	1.6	1.9	2.8
P=23 A=	0.6	0.8	1	1.2	1.4	1.6	1.9	2.8

Mounting Plates Series Omnia L

Linear mounting plates

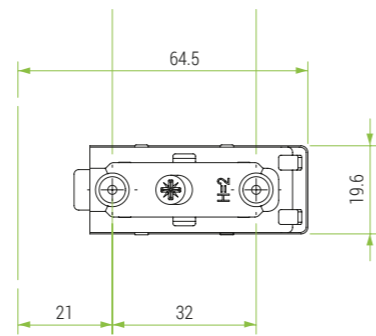
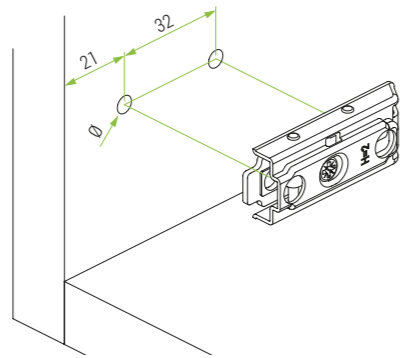

Metal linear mounting plate. Fixing by Selftapping screw. Independent vertical adjustment with CAM.
(For screws see page 25)



Height	Material	Code
H0	Metal	52.LLW0.M9.00.00000
H2	Metal	52.LLW0.M9.02.00000
H4	Metal	52.LLW0.M9.04.00000
H6	Metal	52.LLW0.M9.06.00000

21

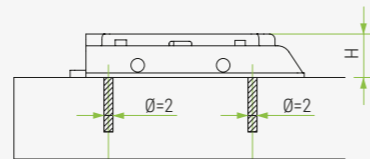

Metal linear mounting plate. Fixing by premounted Euro screws. Independent vertical adjustment with CAM.



Height	Material	Code
H0	Metal	52.LL**.M9.00.00000
H2	Metal	52.LL**.M9.02.00000
H4	Metal	52.LL**.M9.04.00000
H6	Metal	52.LL**.M9.06.00000

** euro screw: ED = L12 / EC = L15

21

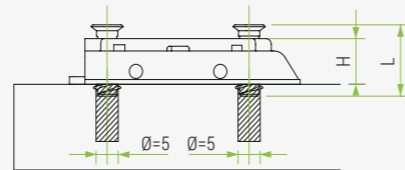

Metal linear mounting plate. Fixing by Expanding dowels Ø5mm. Independent vertical adjustment with CAM.



Height	Material	Code
H0	Metal	52.LL**.M9.00.00000
H2	Metal	52.LL**.M9.02.00000
H4	Metal	52.LL**.M9.04.00000
H6	Metal	52.LL**.M9.06.00000

** dowel: X4 = L7.5 / X5 = L9

21

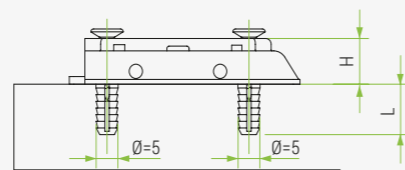

Metal linear mounting plate. Fixing by Knock-in dowels Ø10mm. Independent vertical adjustment with CAM.



Height	Material	Code
H0	Metal	52.LL**.M9.00.00000
H2	Metal	52.LL**.M9.02.00000
H4	Metal	52.LL**.M9.04.00000
H6	Metal	52.LL**.M9.06.00000

** dowel: D8 = Ø8xL10 / D0 = Ø10xL10

21

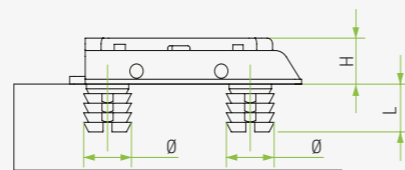

Attention: the picture shows the real product, the drawing shows drilling and mounting instruction.

Cruciform mounting plates

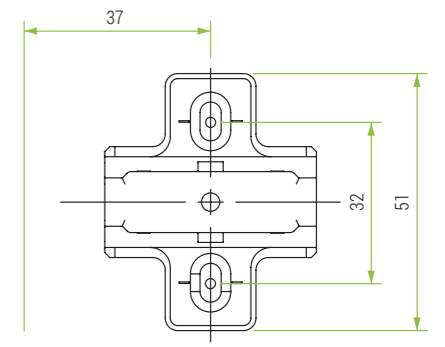
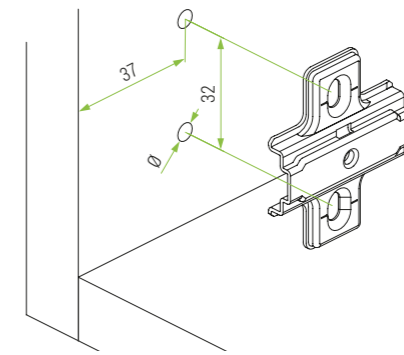

Metal cruciform mounting plate. Fixing by Selftapping screw. Vertical adjustment.
(For screws see page 25)

Height	Material	Code
H0	Metal	52.LCW0.M9.00.00000
H2	Metal	52.LCW0.M9.02.00000
H4	Metal	52.LCW0.M9.04.00000
H6	Metal	52.LCW0.M9.06.00000



37

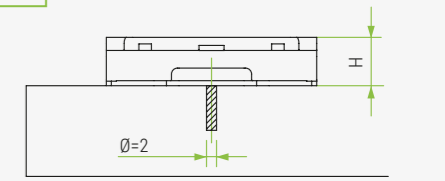

Metal cruciform mounting plate. Fixing by premounted Selftapping screws Ø4.7mm. Vertical adjustment.

Height	Material	Code
H0	Metal	52.LCWP.M9.00.00000
H2	Metal	52.LCWP.M9.02.00000
H4	Metal	52.LCWP.M9.04.00000
H6	Metal	52.LCWP.M9.06.00000



37

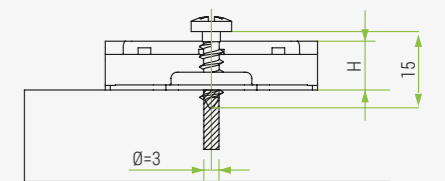

Metal cruciform mounting plate. Fixing by premounted Euro screws. Vertical adjustment.

Height	Material	Code
H0	Metal	52.LC**.M9.00.00000
H2	Metal	52.LC**.M9.02.00000
H4	Metal	52.LC**.M9.04.00000
H6	Metal	52.LC**.M9.06.00000

** euro screw: EH = L10 / ED = L12 / EC = L14



37

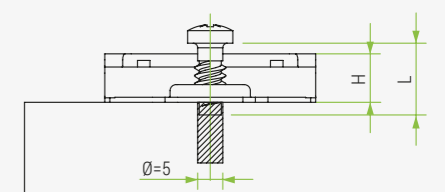

Metal cruciform mounting plate. Fixing by Expanding dowels Ø5mm. Vertical adjustment.

Height	Material	Code
H0	Metal	52.LC**.M9.00.00000
H2	Metal	52.LC**.M9.02.00000
H4	Metal	52.LC**.M9.04.00000
H6	Metal	52.LC**.M9.06.00000

** dowel: X4 = L7.5 / X5 = L9



37

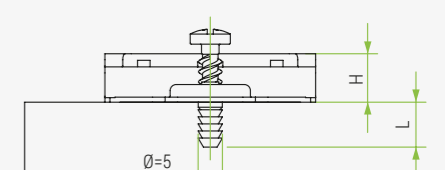

Metal cruciform mounting plate. Fixing by Knock-in dowels Ø10mm. Vertical adjustment.

Height	Material	Code
H0	Metal	52.LC**.M9.00.00000
H2	Metal	52.LC**.M9.02.00000
H4	Metal	52.LC**.M9.04.00000
H6	Metal	52.LC**.M9.06.00000

** dowel: D8 = Ø8xL10 / D0 = Ø10xL10



37

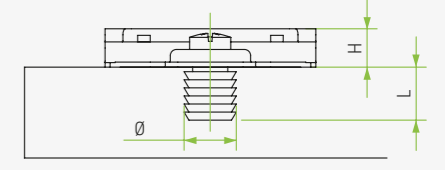

Cruciform mounting plates with CAM

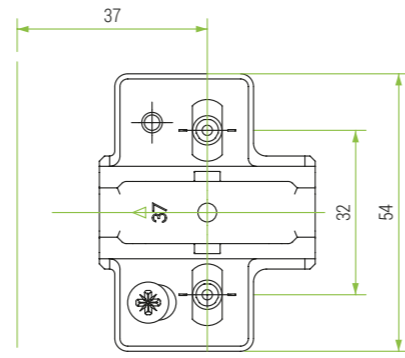
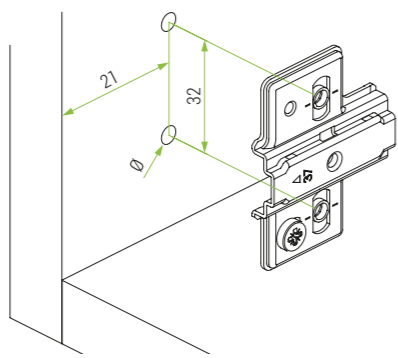

Cruciform mounting plates with CAM

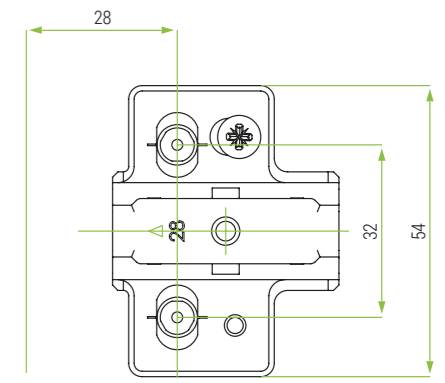
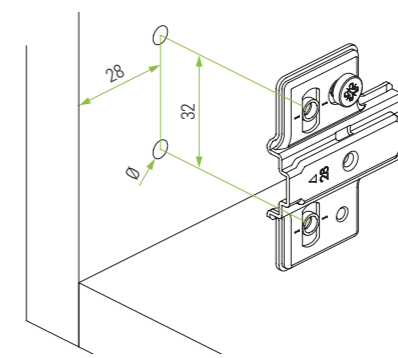

Metal cruciform mounting plate. Fixing by Selftapping screw. Independent vertical adjustment with CAM.
(For screws see page 24)

Height	Material	Code
H0	Metal	52.LDW0.M9.00.00000
H2	Metal	52.LDW0.M9.02.00000
H4	Metal	52.LDW0.M9.04.00000
H6	Metal	52.LDW0.M9.06.00000

37

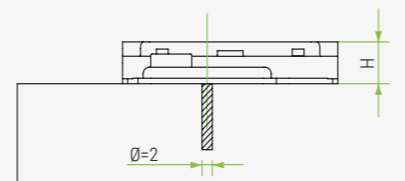

Metal cruciform mounting plate. Fixing by Selftapping screw. Independent vertical adjustment with CAM.
(For screws see page 24)

Height	Material	Code
H0	Metal	52.LBW0.M9.00.00000
H2	Metal	52.LBW0.M9.02.00000
H4	Metal	52.LBW0.M9.04.00000
H6	Metal	52.LBW0.M9.06.00000

28

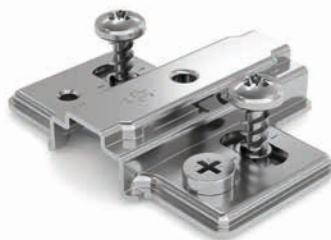
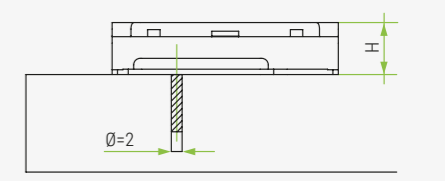

Metal cruciform mounting plate. Fixing by pre-mounted Selftapping screw. Independent vertical adjustment with CAM.

Height	Material	Code
H0	Metal	52.LDWP.M9.00.00000
H2	Metal	52.LDWP.M9.02.00000
H4	Metal	52.LDWP.M9.04.00000
H6	Metal	52.LDWP.M9.06.00000

37

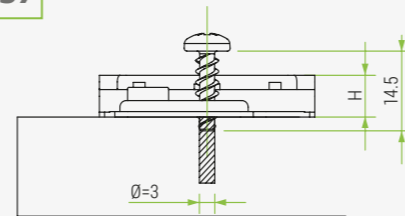

Metal cruciform mounting plate. Fixing by pre-mounted Selftapping screw. Independent vertical adjustment with CAM.

Height	Material	Code
H0	Metal	52.LBWP.M9.00.00000
H2	Metal	52.LBWP.M9.02.00000
H4	Metal	52.LBWP.M9.04.00000
H6	Metal	52.LBWP.M9.06.00000

28

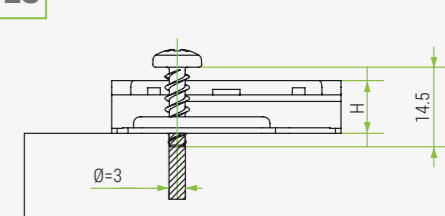

Metal cruciform mounting plate. Fixing by pre-mounted Euro screws. Independent vertical adjustment with CAM.

Height	Material	Code
H0	Metal	52.LD**.M9.00.00000
H2	Metal	52.LD**.M9.02.00000
H4	Metal	52.LD**.M9.04.00000
H6	Metal	52.LD**.M9.06.00000

** euro screw: EH = L10 / ED = L12 / EC = L14

37

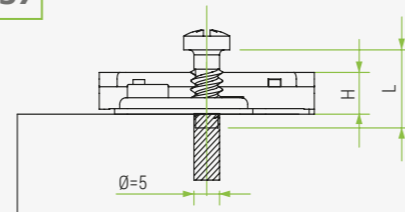

Metal cruciform mounting plate. Fixing by pre-mounted Euro screws. Independent vertical adjustment with CAM.

Height	Material	Code
H0	Metal	52.LB**.M9.00.00000
H2	Metal	52.LB**.M9.02.00000
H4	Metal	52.LB**.M9.04.00000
H6	Metal	52.LB**.M9.06.00000

** euro screw: EH = L10 / ED = L12 / EC = L14

28

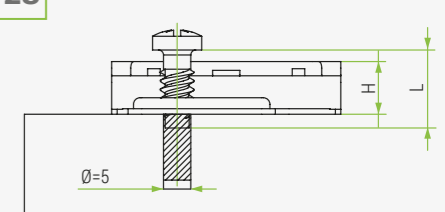

Metal cruciform mounting plate. Fixing by Expanding dowels Ø5mm. Independent vertical adjustment with CAM.

Height	Material	Code
H0	Metal	52.LD**.M9.00.00000
H2	Metal	52.LD**.M9.02.00000
H4	Metal	52.LD**.M9.04.00000
H6	Metal	52.LD**.M9.06.00000

** dowel: X4 = L7.5 / X5 = L9

37

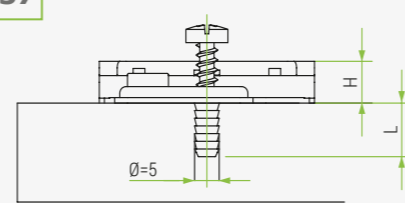

Metal cruciform mounting plate. Fixing by Expanding dowels Ø5mm. Independent vertical adjustment with CAM.

Height	Material	Code
H0	Metal	52.LB**.M9.00.00000
H2	Metal	52.LB**.M9.02.00000
H4	Metal	52.LB**.M9.04.00000
H6	Metal	52.LB**.M9.06.00000

** dowel: X4 = L7.5 / X5 = L9

28

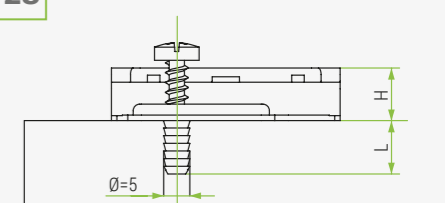

Metal cruciform mounting plate. Fixing by Knock-in dowels Ø10mm. Independent vertical adjustment with CAM.

Height	Material	Code
H0	Metal	52.LD**.M9.00.00000
H2	Metal	52.LD**.M9.02.00000
H4	Metal	52.LD**.M9.04.00000
H6	Metal	52.LD**.M9.06.00000

** dowel: D8 = Ø8xL10 / D0 = Ø10xL10

37

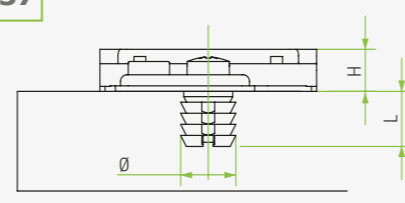

Metal cruciform mounting plate. Fixing by Knock-in dowels Ø10mm. Independent vertical adjustment with CAM.

Height	Material	Code
H0	Metal	52.LB**.M9.00.00000
H2	Metal	52.LB**.M9.02.00000
H4	Metal	52.LB**.M9.04.00000
H6	Metal	52.LB**.M9.06.00000

** dowel: D8 = Ø8xL10 / D0 = Ø10xL10

28

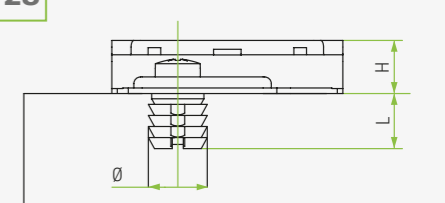

Face frame mounting plates

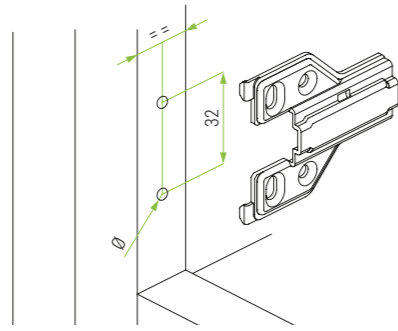

Metal face frame mounting plate. Fixing by Selftapping screw. Vertical adjustment.
(For screws see page 25)

Height	Material	Code
H0	Metal	52.LFW0.M9.00.00000
H3	Metal	52.LFW0.M9.03.00000

9.5

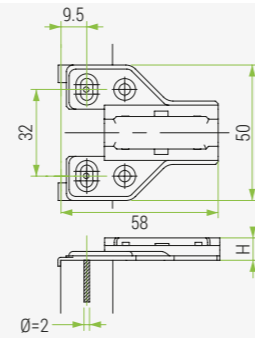

Metal face frame mounting plate. Fixing by Selftapping screw. Vertical adjustment.
(For screws see page 25)

Height	Material	Code
H0	Metal	52.LHW0.M9.00.00000
H3	Metal	52.LHW0.M9.03.00000

12.5

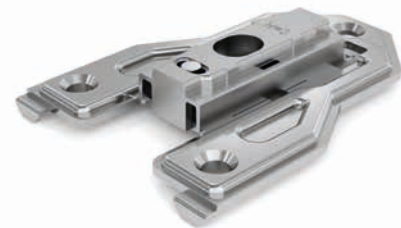
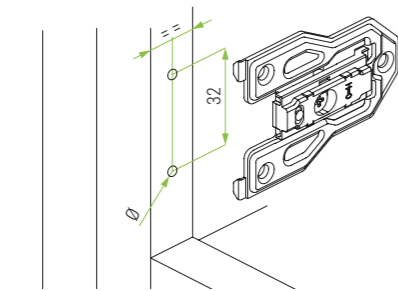
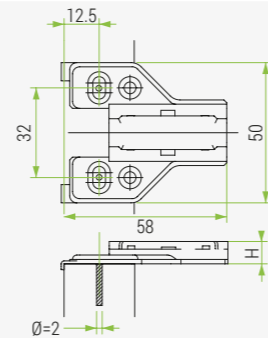

Metal face frame mounting plate. Fixing by Selftapping screw. Independent vertical adjustment with CAM.
(For screws see page 25)

Height	Material	Code
H0	Metal	52.LGW0.M9.00.00000
H3	Metal	52.LGW0.M9.03.00000

9.5

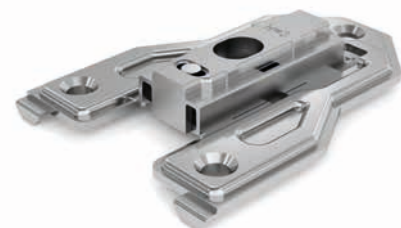
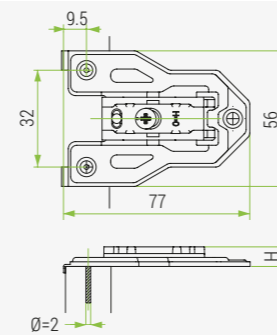

Metal face frame mounting plate. Fixing by Selftapping screw. Independent vertical adjustment with CAM.
(For screws see page 25)

Height	Material	Code
H0	Metal	52.LIW0.M9.00.00000
H3	Metal	52.LIW0.M9.03.00000

12.5

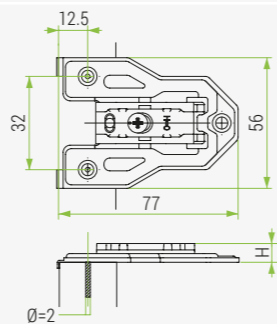

Asymmetric mounting plates (for central panel)

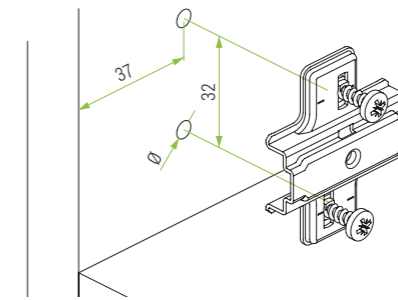
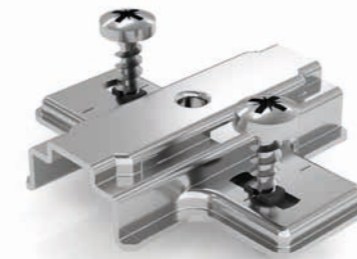

Metal asymmetric mounting plate for central panel. Fixing by Expanding dowels Ø5mm. Vertical adjustment.

Height	Material	Code
H0	Metal	52.LND5.M9.00.00000
H2	Metal	52.LND5.M9.02.00000
H4	Metal	52.LND5.M9.04.00000
H6	Metal	52.LND5.M9.06.00000

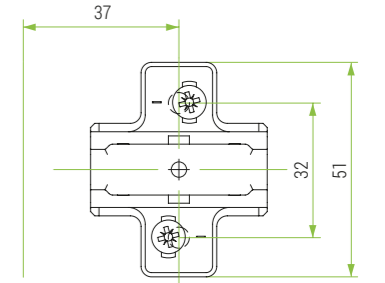

37

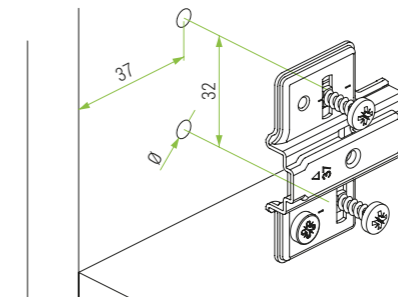
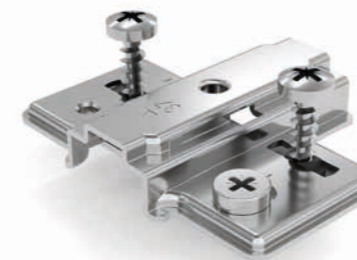
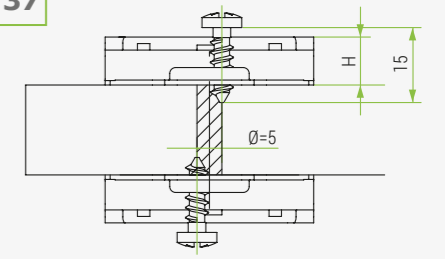

Metal asymmetric mounting plate for central panel. Fixing by Expanding dowels Ø5mm. Independent vertical adjustment with CAM.

Height	Material	Code
H0	Metal	52.LQD5.M9.00.00000
H2	Metal	52.LQD5.M9.02.00000
H4	Metal	52.LQD5.M9.04.00000
H6	Metal	52.LQD5.M9.06.00000

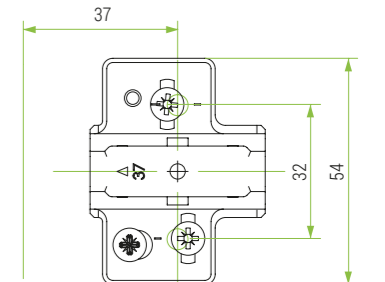

37

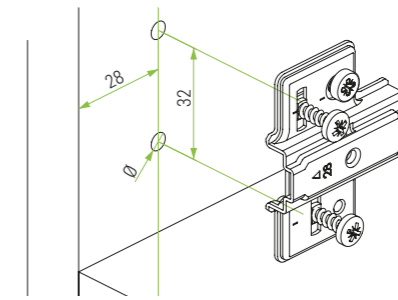
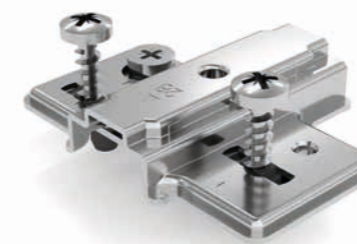
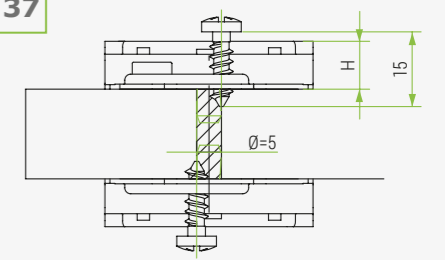

Metal asymmetric mounting plate for central panel. Fixing by Expanding dowels Ø5mm. Independent vertical adjustment with CAM.

Height	Material	Code
H0	Metal	52.LPD5.M9.00.00000
H2	Metal	52.LPD5.M9.02.00000
H4	Metal	52.LPD5.M9.04.00000
H6	Metal	52.LPD5.M9.06.00000

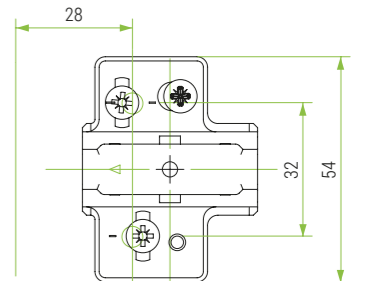

28

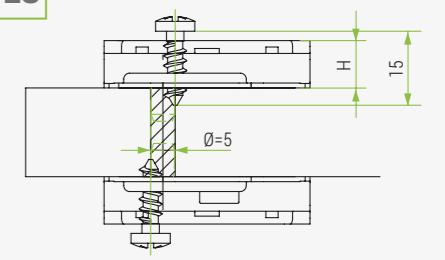



Technical Specifications:

- Stopper device 95°
- Application with Omnia L hinge Crank 0, 8, 15 and Angle 24°±30°, 45°, 90°
- Made in black plastic

Opening angle stopper

Code	Description	Packing
51.LA00.03.0000000	Opening angle stopper	5000 pcs

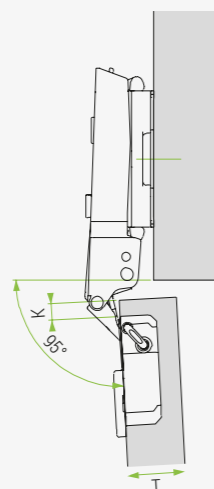
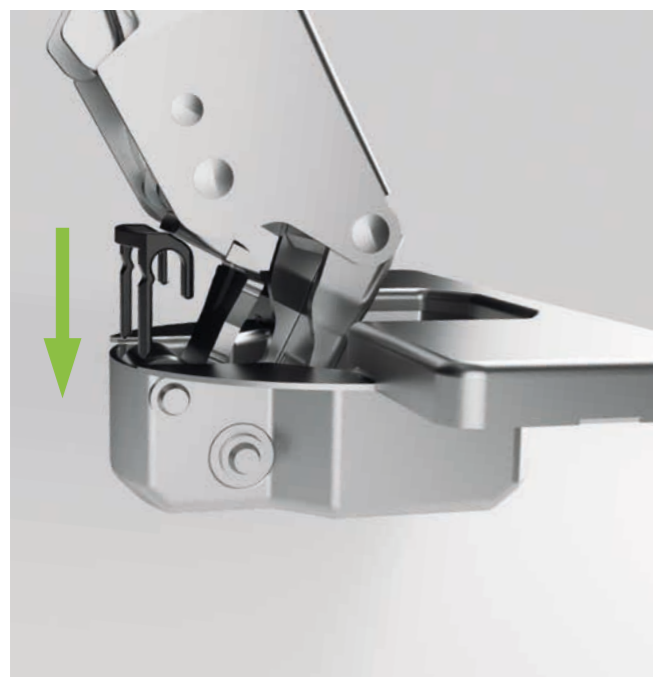

T=	14	15	16	17	18	19	20	21	22	23	24	25	26	27	28	29	30
K=3	A= 0.1	0.2	0.3	0.4	0.5	0.7	0.8	1	1.2	1.4	1.6	2.4	3.2	4.1	5	5.9	6.8
K=4	A= 0.1	0.2	0.3	0.4	0.5	0.6	0.8	1	1.2	1.4	1.6	2	2.8	3.6	4.4	5.3	6.2
K=5	A= 0.1	0.2	0.3	0.3	0.5	0.6	0.8	1	1.2	1.4	1.6	1.9	2.5	3.2	4	4.8	5.6
K=6	A= 0.1	0.2	0.3	0.3	0.5	0.6	0.8	1	1.2	1.4	1.6	1.9	2.3	2.9	3.6	4.4	5.2
K=7	A= 0.1	0.2	0.3	0.3	0.5	0.6	0.8	1	1.2	1.4	1.6	1.9	2.1	2.7	3.4	4.1	4.8



Selftapping screws with countersunk and Pozi drive head, nickel finish, for hinge and mounting plate fixing.

Ø	Length	Material	Code
4	12.5	Steel	1A035034150CF
4	15.5	Steel	1A035034250CF



Selftapping screws with Flat and Pozi drive head, nickel finish, for hinge and mounting plate fixing.

Ø	Length	Material	Code
4	12.5	Steel	1A003076015CF
4	15.5	Steel	1A003076025CF



Euro screws with Pozi drive head, nickel finish, for mounting plate fixing.

Ø	Length	Material	Code
6.3	10	Steel	1A035034150CF
6.3	12	Steel	1A035034250CF
6.3	14	Steel	1A075108150CF



Euro screws with Pozi drive head, nickel finish, for hinge fixing.

Ø	Length	Material	Code
6.3	12	Steel	1A075130050CF



Dowel in nylon for hinge fixing.

Ø	Height	Material	Code
10	12	Nylon	2H011070530CF
8	11	Nylon	2H000449003CF

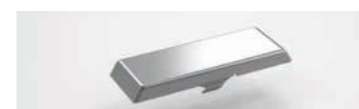

Hinge Arm cover cap.

Application	Material	Code
For Crank 0 and Angles	Steel	51LM00M90000000
For Crank 8	Steel	51LM00M90100000

*with Customer logo upon request



Hinge box cover cap.

Cup hole distance	Material	Code
I.48 / A.45 / D.52	Steel	51LC00M90000000

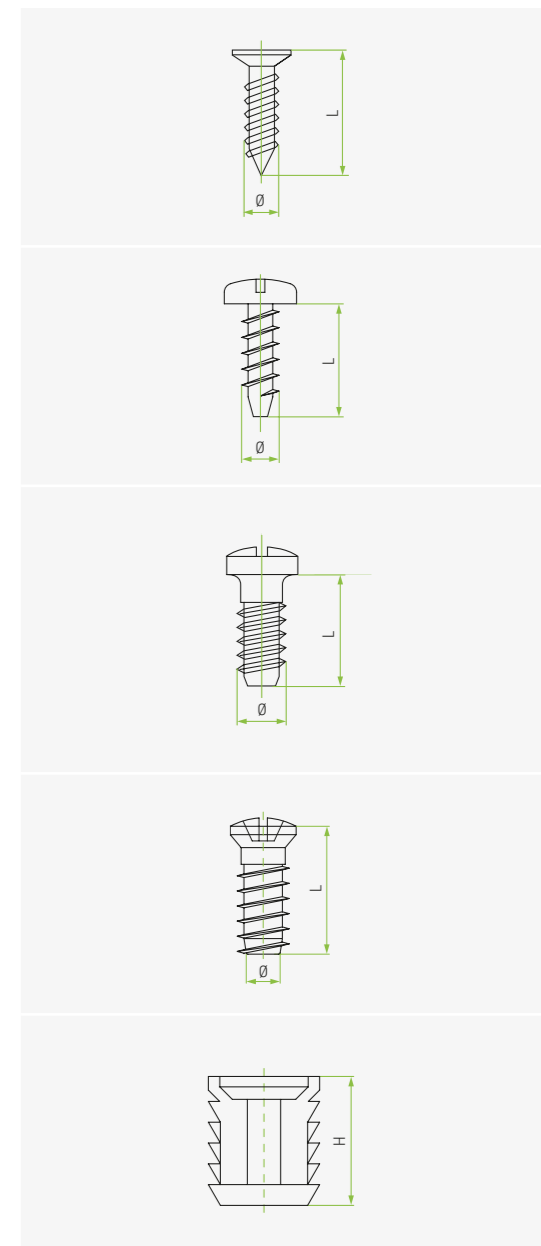

HINGES

Fixing System



SELFTAPPING SCREW

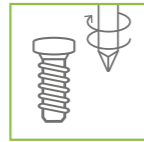

EURO SCREW

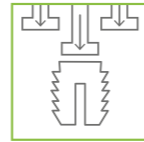

DOWEL

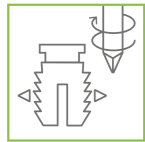

VELOFIX DOWEL

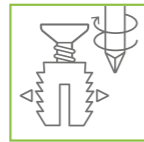

EXPANDING DOWEL

Cup hole distance

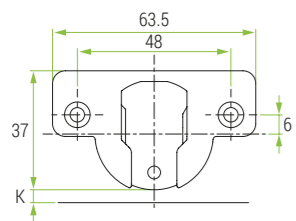

I48

CUP HOLE DISTANCE 48x6 mm

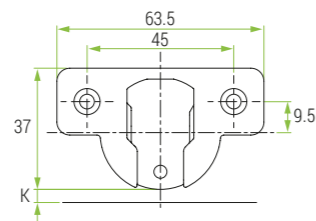

A45

CUP HOLE DISTANCE 45x9.5 mm

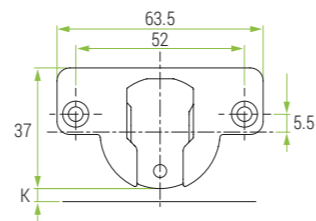

D52

CUP HOLE DISTANCE 52x5.5 mm

Angles



90°

OPENING

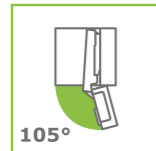

105°

OPENING



105°

OPENING



155°

OPENING

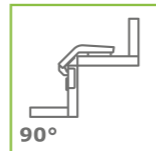

90°

OPENING



105°

OPENING

MOUNTING PLATES

Fixing System

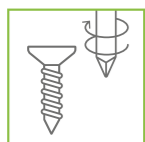

SELFTAPPING SCREW

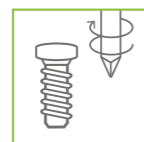

EURO SCREW

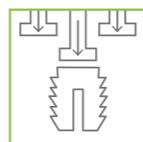

DOWEL

21

DRILLING DISTANCE 21 mm

28

DRILLING DISTANCE 28 mm

37

DRILLING DISTANCE 37 mm

9.5

DRILLING DISTANCE 9.5 mm

12.5

DRILLING DISTANCE 12.5 mm

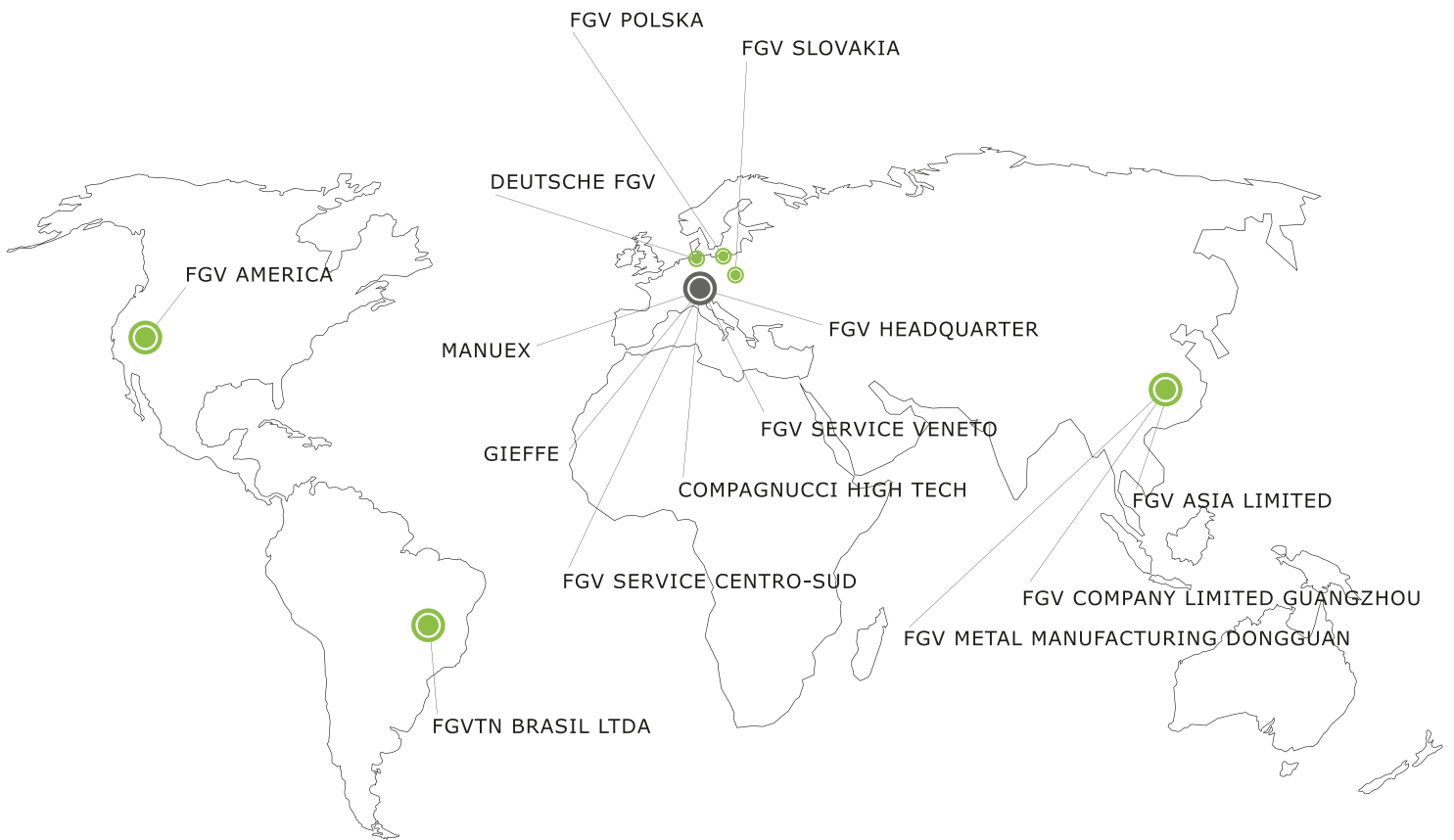

DISCOVER ALL THE OFFICES IN THE WORLD



FORMENTI & GIOVENZANA S.P.A.
Via Concordia, 16 - 20837 Veduggio con Colzano (MB) - Italy
T. +39 (0)362 9471 - F. +39 (0)362 998788 - info@fgv.it - www.fgv.it