

# 2021

## PROCYON MEETING PODS

by Silent Business Solutions



EUROPEAN DESIGN.  
MADE FOR THE AMERICAN MARKET.

# ACOUSTIC AND CONFIDENTIALITY SOLUTIONS

## OUR COMMITMENTS

*Enjoy your work!*



Silent ventilation. Our team of engineers has developed one of the best ventilation systems that are both powerful and indiscernible.



Comfortable, spacious, ergonomic and functional working spaces.



Equipped with a whiteboard desk, outlets and LED Lights.

## CUSTOMIZATION

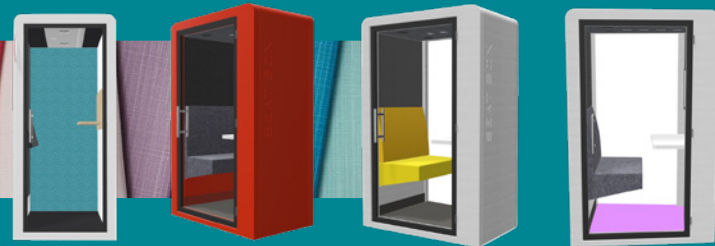

**Acoustic Panels** - 8 Color fabrics available



**Exterior Finish** - 41 Color possibilities



**Seat & Back** - 165 Color choices



**Floor & Ceiling** - 2 Colors Available







# CLEAN-AIR SYSTEM

Boost your health and productivity in the workspace

The **FIRST** soundproof personal space that:

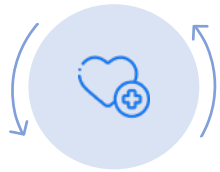

Disinfects and Purifies the air you breathe, including Coronavirus.



Easily integrates in open-plan settings - whatever the size.

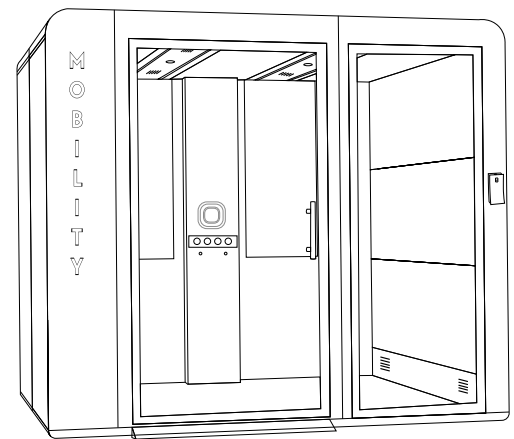
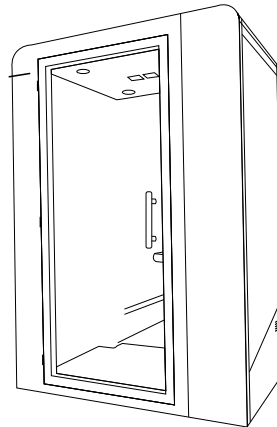
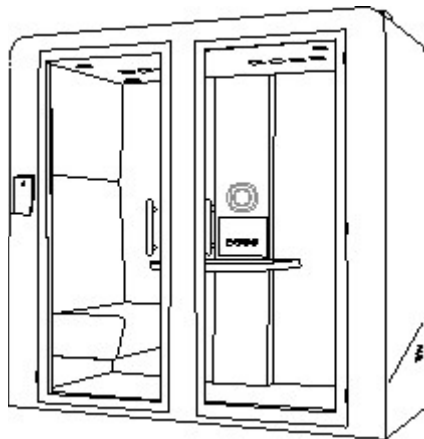

Safe, healthy and “worry free” environment for your employees.



Privacy, comfort and technology to boost productivity.



A turnkey solution: highly flexible that can be easily adapted by all open-plan offices whatever the space, size and need.

## AIR AND SURFACE PURIFICATION SYSTEM

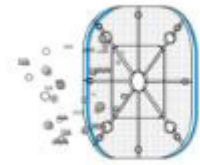

### Pre-Filter

The First Layer targets large particles. Including dust, insects and animal hair.

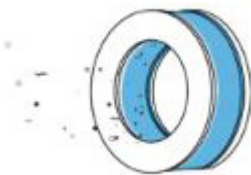

### Ray-Filter™

Patented Ray Filter consists of 3 unique antibacterial layers that target fine particles (PM 2.5 and 10), germs, odors, bacteria, viruses, fungus and mold spores.

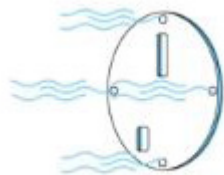

### UVC LEDs

Kill bacteria, viruses and parasites by destroying their integral membrane protein.



### Sterionizer™

Creates pure air by releasing positive and negative ions to freshen up the pod and removes any remaining harmful pollutants.



### DATA MONITORING

Track in real time the quality of the air inside your booth.



Connects to **Google Assistant** and **Alexa**

# PROCYON SEAT BOX

Dimensions: 47 x 33 x 75

A personal workspace designed for private phone conversation, light concentrated work and video calls.



Confidentiality Pod  
1 Person



## ACOUSTIC

Excellent sound insulation of 45 dBA.

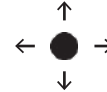

## MOBILE

Equipped with casters. Procyon moves and adapts easily to your needs of evolution with a simple and fast installation.



## ARS (Optional)

Equipped with a patented air cooling system, ARS Air Refreshing System.

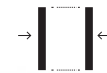

## COMPACT

With minimal floor surfaces, our solutions are adaptable to all office spaces.



## CUSTOMIZABLE

Thousands of possible combinations with materials and finishes carefully tested and selected.

# INDIVIDUAL RANGE

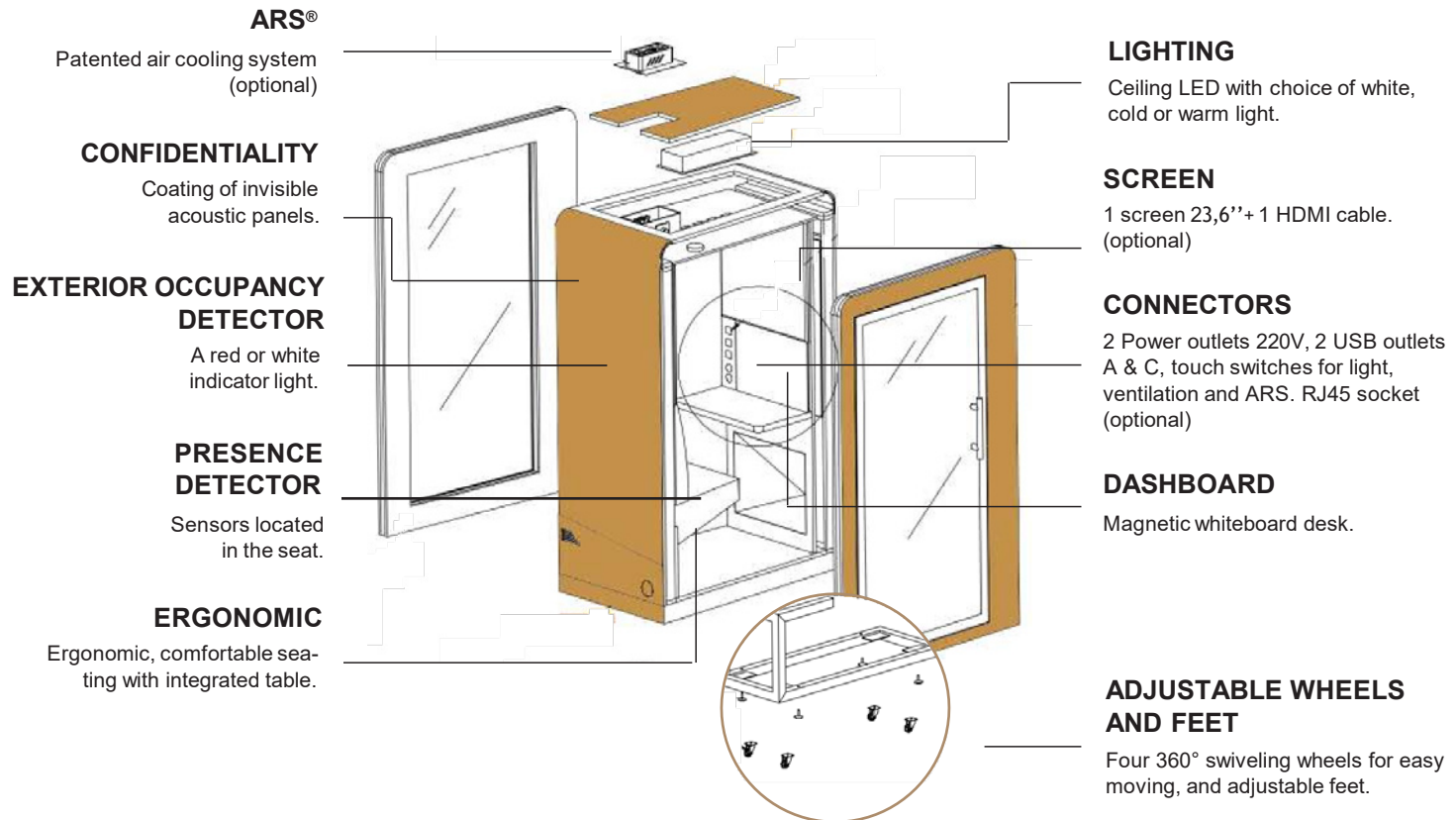

## INCLUDED

- 1 Built-in extra comfortable foam bench
- Work Desk - Matching to external color
- Occupancy sensor triggering lighting
- Input 110 - 240 V / 1 power socket + USB A & C
- Ceiling LED light (soft white light)
- Dashboard for controlling light intensity, ventilation & temperature
- Extra powerful ventilation (2 silent ventilators)
- 4 adjustable feet and casters to move and relocate the pod

## OPTIONAL

- ARS (Air Refreshing System) to cool the booth
- 23.6" screen + HDMI Socket
- Logo embossment (your own logo!)
- Confidential window film
- 2 RJ45 socket

# PROCYON STAND UP

Dimensions: 37 x 37 x 86

A pod designed for private phone conversations and quick note-taking without interrupting the surrounding people.



Confidentiality Pod  
1 Person



## ACOUSTIC

Excellent sound insulation of 45 dBA.

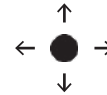

## MOBILE *(Optional)*

Equipped with casters. Procyon moves and adapts easily to your needs of evolution with a simple and fast installation.



## ARS *(Optional)*

Equipped with a patented air cooling system, ARS Air Refreshing System.



## COMPACT

With minimal floor surfaces, our solutions are adaptable to all office spaces.



## CUSTOMIZABLE

Thousands of possible combinations with materials and finishes carefully tested and selected.



# INDIVIDUAL RANGE

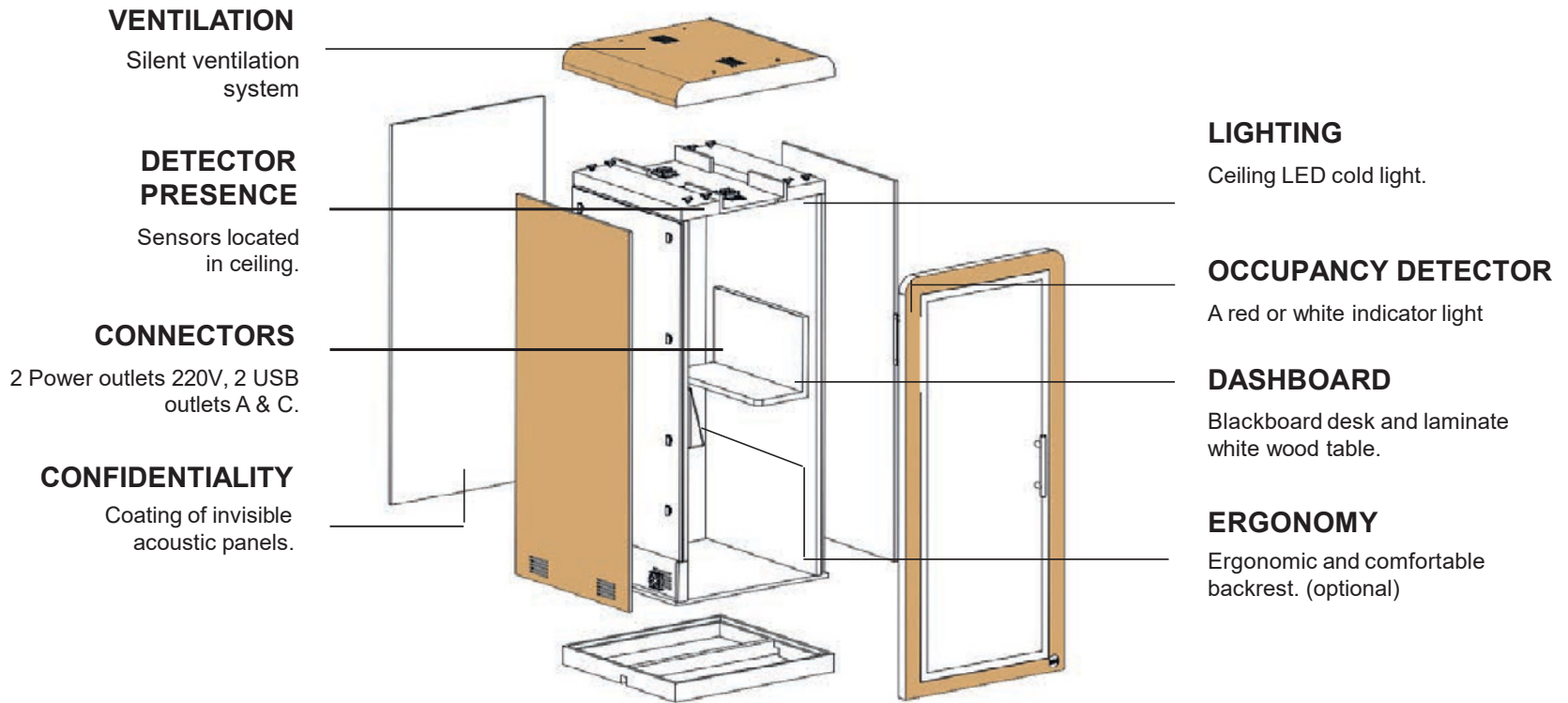

## INCLUDED

- Work Desk - Matching to external color
- Occupancy sensor triggering lighting
- Input 110 - 240 V / 1 power socket + USB A & C
- Ceiling LED light (soft white light)
- Extra powerful ventilation (2 silent ventilators)

## OPTIONAL

- Back cushion
- Foot rest
- 4 adjustable feet and casters to move and relocate the pod
- Half-glass back panel
- Confidential window film

# PROCYON UNO

Dimensions: 47 x 33 x 75



Confidentiality Pod  
1 Person

A personal workspace solution designed for private phone conversation, extended concentrated work and video calls.



## ACOUSTIC



Excellent sound insulation of 45 dBA.

## MOBILE *(Optional)*

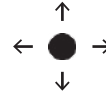

Equipped with casters. Procyon moves and adapts easily to your needs of evolution with a simple and fast installation.

## ARS *(Optional)*



Equipped with a patented air cooling system, ARS Air Refreshing System.

## COMPACT

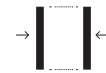

With minimal floor surfaces, our solutions are adaptable to all office spaces.

## CUSTOMIZABLE



Thousands of possible combinations with materials and finishes carefully tested and selected.

# INDIVIDUAL RANGE

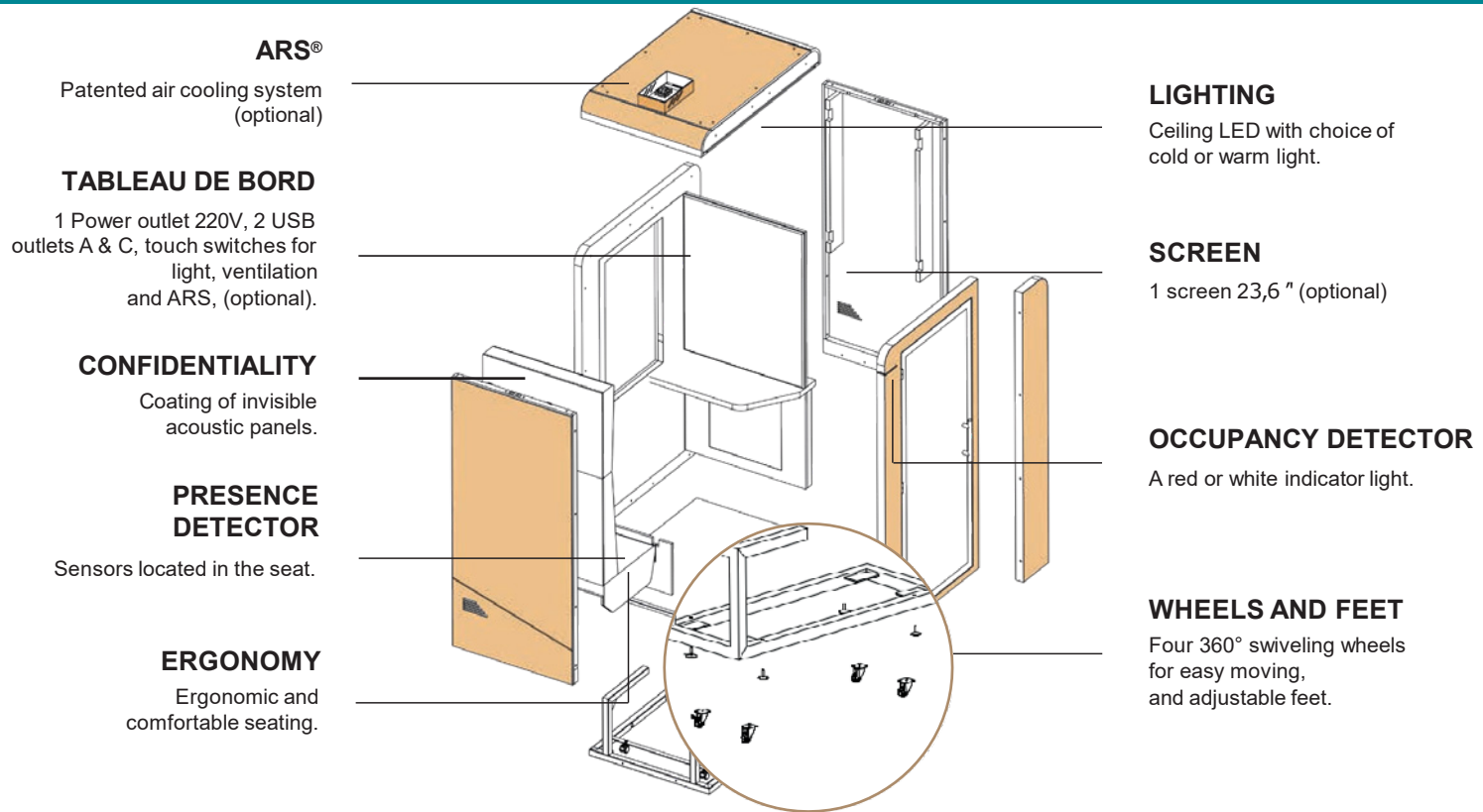

## INCLUDED

- 1 Built-in extra comfortable foam bench
- Work Desk - Matching to external color
- Occupancy sensor triggering lighting
- Input 110 - 240 V / 1 power socket + USB A & C
- Ceiling LED light (soft white light)
- Dashboard for controlling light intensity, ventilation & temperature
- Extra powerful ventilation (2 silent ventilators)
- 4 adjustable feet and casters to move and relocate the pod
- 23.6" screen + HDMI Socket

## OPTIONAL

- ARS (Air Refreshing System) to cool the booth
- Logo embossment (your own logo!)
- Half-glass back panel
- Confidential window film
- 2 RJ45 socket

# PROCYON DUO

Dimensions: 85 x 40 x 83

A silent workspace for two. Designed for private meetings, conversation, presentations, extended concentrated work, and video calls. Compatible with AURA Clean-Air system for a cleaner and safer work environment.



Informal Meeting Space  
2 People



## ACOUSTIC

Excellent sound insulation of 45 dBA.

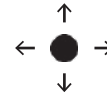

## MOBILE *(Optional)*

Equipped with casters. Procyon moves and adapts easily to your needs of evolution with a simple and fast installation.



## ARS *(Optional)*

Equipped with a patented air cooling system, ARS Air Refreshing System.



## COMPACT

With minimal floor surfaces, our solutions are adaptable to all office spaces.



## CUSTOMIZABLE

Thousands of possible combinations with materials and finishes carefully tested and selected.



# COLLABORATIVE RANGE

## CONNECTORS

2 Power outlets 220V, 2 USB outlets A & C & 2 Power outlets HDMI. Touch switches for light, ventilation and ARS. RJ45 socket (optional).

**ARS®**  
Patented air cooling system (optional)

**CONFIDENTIALITY**  
Coating of invisible acoustic panels.

**PRESENCE DETECTOR**  
Sensors located in the seat.

**ERGONOMY**  
Ergonomic and comfortable seating

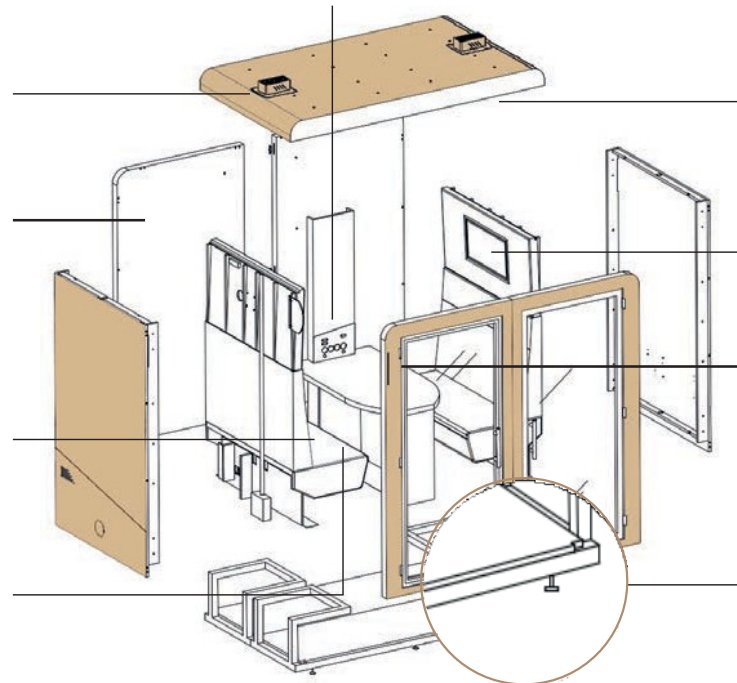

## LIGHTING

Ceiling LED with choice of cold or warm light.

## SCREEN

2 integrated and backlit screens 23,6" subframe anthracite.

## OCCUPANCY DETECTOR

A red or white indicator light.

## WHEELS AND FEET

Twelve 360° swiveling wheels for easy moving, and adjustable feet.

## INCLUDED

- 2 Built-in extra comfortable foam benches
- Work Table - Matching to external color
- Occupancy sensor triggering lighting
- Input 110 - 240 V / 1 power socket + USB A & C
- Ceiling LED light (soft white light)
- Dashboard for controlling light intensity, ventilation & temperature
- Extra powerful ventilation (4 silent ventilators)
- 12 adjustable feet and casters to move and relocate the pod
- 2 x 23.6" screens + HDMI Socket

## OPTIONAL

- ARS (Air Refreshing System) to cool the booth
- Clean-Air system by Aura-Air
- Logo embossment (your own logo!)
- Half-glass back panel
- Confidential window film
- RJ45 socket

# PROCYON QUATRO

Dimensions: 85 x 55 x 83

A silent workspace for four. Designed for private meetings, conversation, presentations, extended concentrated work, and video calls. Compatible with AURA Clean-Air system for a cleaner and safer work environment.



Informal Meeting Space  
4 People



## ACOUSTIC

Excellent sound insulation of 45 dBA.

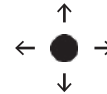

## MOBILE *(Optional)*

Equipped with casters. Procyon moves and adapts easily to your needs of evolution with a simple and fast installation.



## ARS *(Optional)*

Equipped with a patented air cooling system, ARS Air Refreshing System.

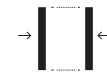

## COMPACT

With minimal floor surfaces, our solutions are adaptable to all office spaces.



## CUSTOMIZABLE

Thousands of possible combinations with materials and finishes carefully tested and selected.

# COLLABORATIVE RANGE

## CONNECTORS

2 Power outlets 220V, 2 USB outlets A & C & 2 Power outlets HDMI. Touch switches for light, ventilation and ARS. RJ45 socket (optional).

**ARS®**  
Patented air cooling system (optional)

**CONFIDENTIALITY**  
Coating of invisible acoustic panels.

**PRESENCE DETECTOR**  
Sensors located in the seat.

**ERGONOMY**  
Ergonomic and comfortable seating

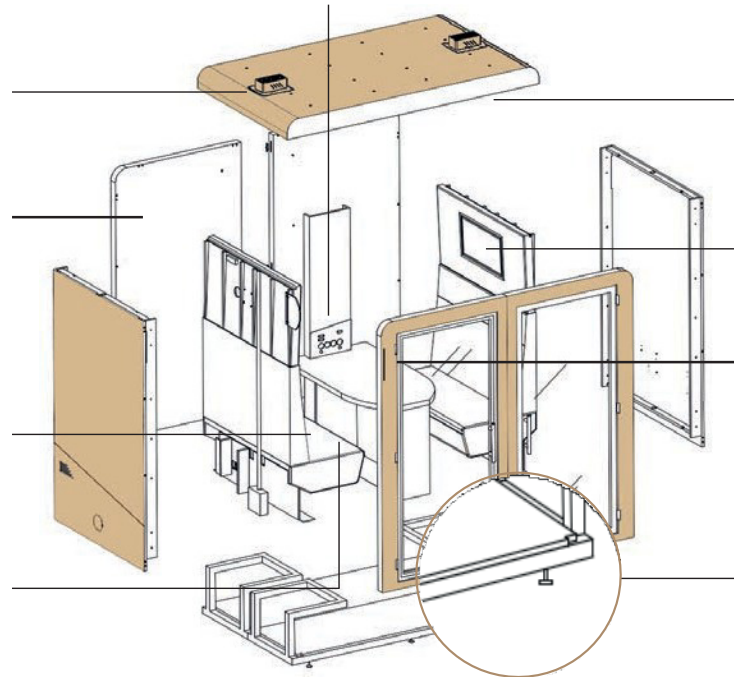

## LIGHTING

Ceiling LED with choice of cold or warm light.

## SCREEN

2 integrated and backlit screens 23,6" subframe anthracite.

## OCCUPANCY DETECTOR

A red or white indicator light.

## WHEELS AND FEET

Twelve 360° swiveling wheels for easy moving, and adjustable feet.

## INCLUDED

- 2 Built-in extra comfortable foam benches
- Work Table - Matching to external color
- Occupancy sensor triggering lighting
- Input 110 - 240 V / 1 power socket + USB A & C
- Ceiling LED light (soft white light)
- Dashboard for controlling light intensity, ventilation & temperature
- Extra powerful ventilation (6 silent ventilators)
- 12 adjustable feet and casters to move and relocate the pod
- 2 x 23.6" screens + HDMI Socket

## OPTIONAL

- ARS (Air Refreshing System) to cool the booth
- Clean-Air system by Aura-Air
- Logo embossment (your own logo!)
- Half-glass back panel
- Confidential window film
- 2 RJ45 socket

# PROCYON SIXO

Dimensions: 85 x 65 x 83



Informal Meeting Space  
6 People

A silent workspace for six. Designed for private meetings, conversation, presentations, extended concentrated work, and video calls. Compatible with AURA Clean-Air system for a cleaner and safer work environment.

## ACOUSTIC



Excellent sound insulation of 45 dBA.

## MOBILE *(Optional)*

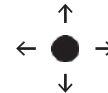

Equipped with casters. Procyon moves and adapts easily to your needs of evolution with a simple and fast installation.

## ARS *(Optional)*



Equipped with a patented air cooling system, ARS Air Refreshing System.

## COMPACT

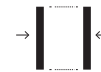

With minimal floor surfaces, our solutions are adaptable to all office spaces.

## CUSTOMIZABLE



Thousands of possible combinations with materials and finishes carefully tested and selected.





# COLLABORATIVE RANGE

## CONNECTORS

2 Power outlets 220V, 2 USB outlets A & C & 2 Power outlets HDMI. Touch switches for light, ventilation and ARS. RJ45 socket (optional).

**ARS®**  
Patented air cooling system (optional)

**CONFIDENTIALITY**  
Coating of invisible acoustic panels.

**PRESENCE DETECTOR**  
Sensors located in the seat.

**ERGONOMY**  
Ergonomic and comfortable seating

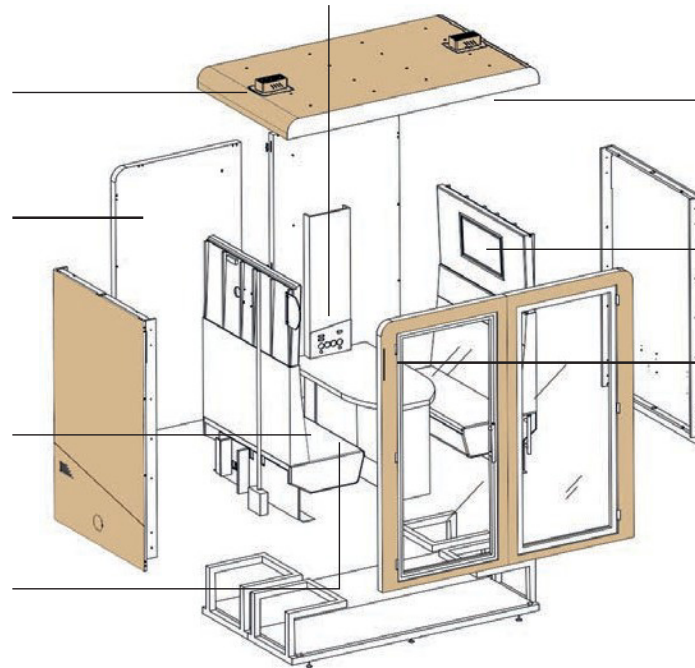

## LIGHTING

Ceiling LED with choice of cold or warm light.

## SCREEN

2 integrated and backlit screens 23,6" subframe anthracite.

## OCCUPANCY DETECTOR

A red or white indicator light.

## INCLUDED

- 2 Built-in extra comfortable foam benches
- Work Table - Matching to external color
- Occupancy sensor triggering lighting
- Input 110 - 240 V / 1 power socket + USB A & C
- Ceiling LED light (soft white light)
- Dashboard for controlling light intensity, ventilation & temperature
- Extra powerful ventilation (6 silent ventilators)
- 12 adjustable feet and casters to move and relocate the pod
- 2 x 23.6" screens + HDMI Socket

## OPTIONAL

- ARS (Air Refreshing System) to cool the booth
- Clean-Air system by Aura-Air
- Logo embossment (your own logo!)
- Half-glass back panel
- Confidential window film
- 2 RJ45 socket

# PROCYON MOBILITY

Dimensions: 98 x 71 x 87



Informal Meeting Space  
4 People

An inclusive and silent workspace for four. Designed for private meetings, conversation, presentations, extended concentrated work, and video calls with integrated wheelchair accessible ramps. Compatible with AURA Clean-Air system for a cleaner and safer work environment.



## ACOUSTIC

Excellent sound insulation of 45 dBA.



## ADA

Space suitable for wheelchairs and equipped with an access ramp.



## ARS (Optional)

Equipped with a patented air cooling system, ARS Air Refreshing System.



## COMPACT

With minimal floor surfaces, our solutions are adaptable to all office spaces.



## CUSTOMIZABLE

Thousands of possible combinations with materials and finishes carefully tested and selected.

# COLLABORATIVE RANGE

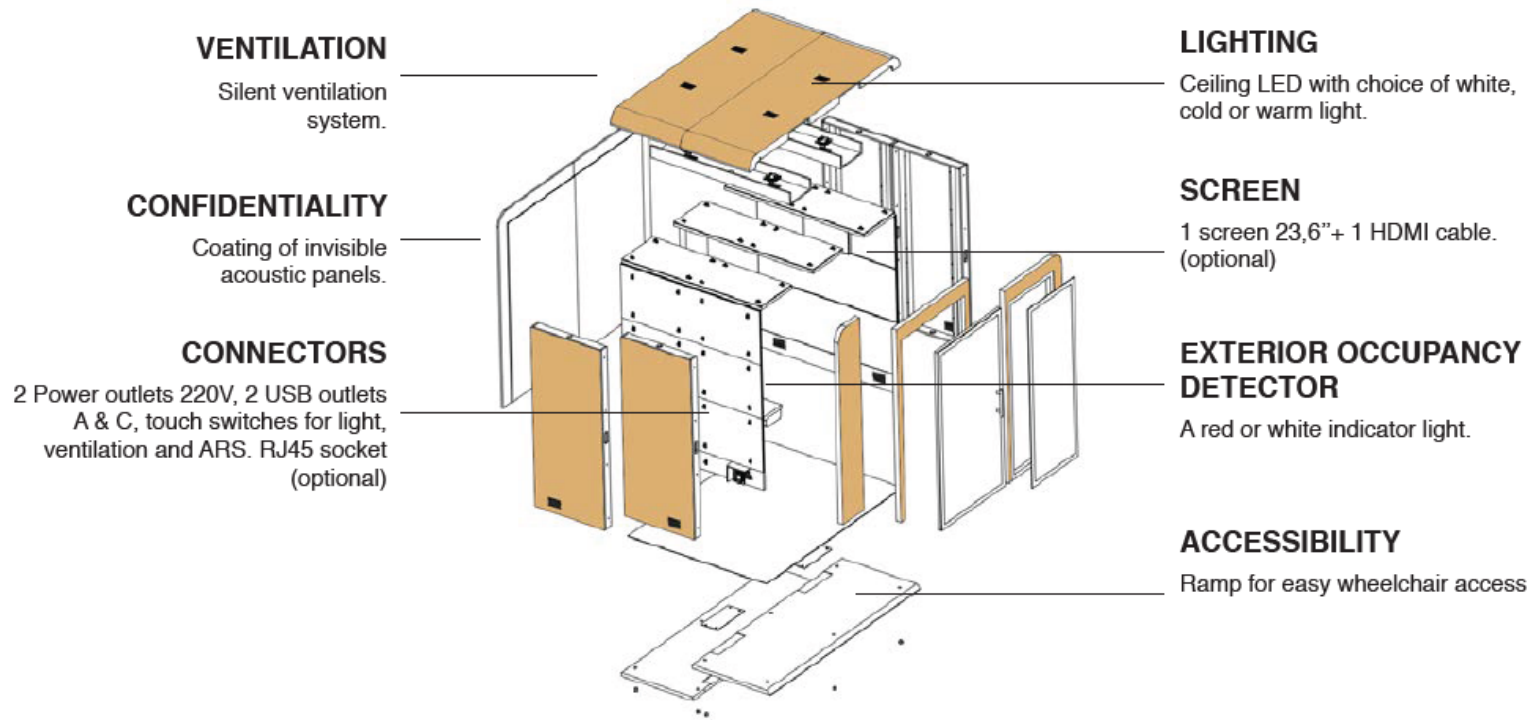

## INCLUDED

- 2 Built-in extra comfortable foam benches
- Extra wide work table - Matching to external color
- Occupancy sensor triggering lighting
- Input 110 - 240 V / 1 power socket + USB A & C
- Ceiling LED light (soft white light)
- Dashboard for controlling light intensity, ventilation & temperature
- Extra powerful ventilation (6 silent ventilators)
- Wheelchair access ramp to facilitate entry

## OPTIONAL

- ARS (Air Refreshing System) to cool the booth
- Clean-Air system by Aura-Air
- 23.6" screen + HDMI Socket
- Logo embossment (your own logo!)
- Half-glass back panel
- Confidential window film
- 2 RJ45 socket

# PROCYON DREAM BOX

Dimensions: 99 x 52 x 82



Space for Individual  
Power Naps

A personal quiet place designed for power-naps that improves working performance.

20 minutes can help increase productivity by up to 35%.

Reduces stress, increases creativity, improves concentration and general health.



## ACOUSTIC

Excellent sound insulation  
of 45 dBA.



## ARS (Optional)

Equipped with a patented air cooling  
system, ARS Air Refreshing System.



## COMPACT

With minimal floor surfaces, our  
solutions are adaptable to all office  
spaces.



## CUSTOMIZABLE

Choice of 9 wood colors for exterior  
and 25 colors for the mattress cover.  
Internal parts are always white.



# WELL-BEING COCOON

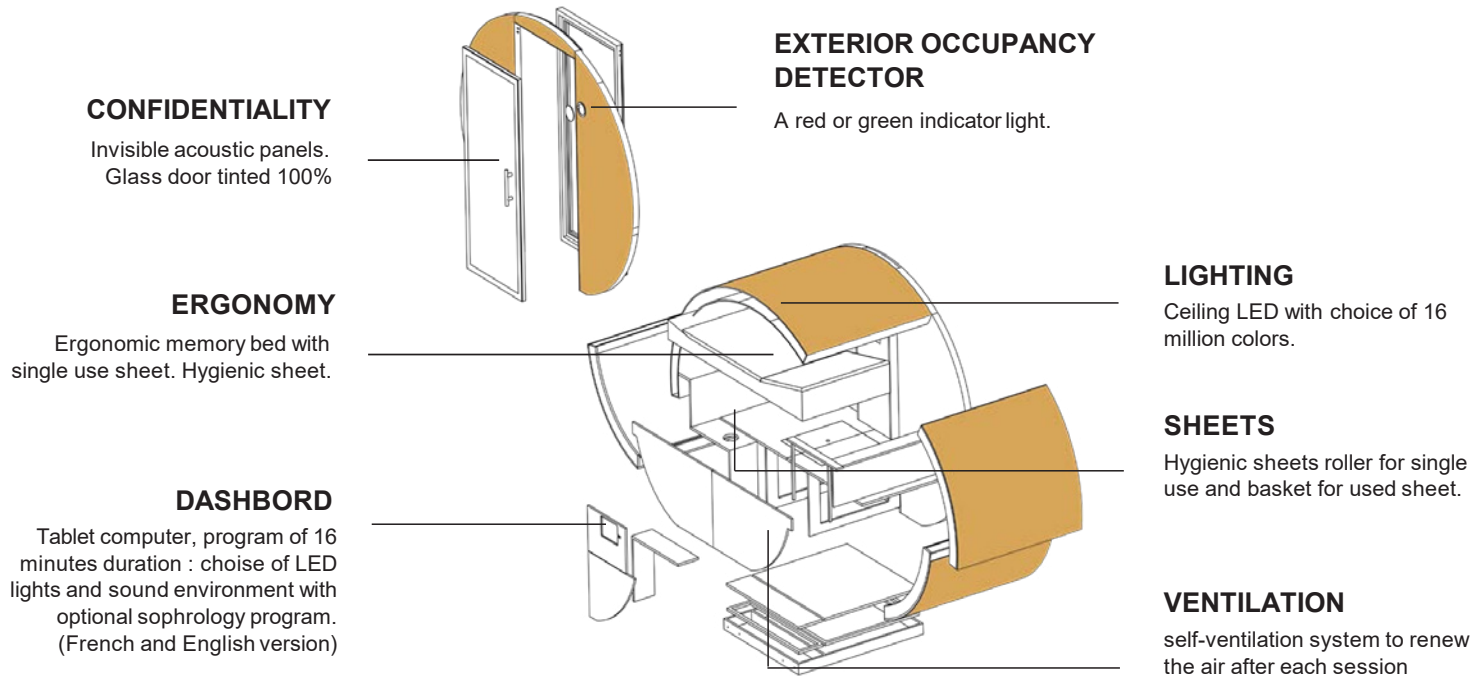

## INCLUDED

- Ergonomic memory bed with single use hygienic sheet.
- 100% tinted glass door
- Occupancy sensor triggering lighting
- Input 110 - 240 V / 1 power socket + USB A & C
- Ceiling LED light (soft white light)
- Dashboard for controlling light intensity, ventilation & temperature
- Self-ventilation system to renew the air after each session
- 2 x 23.6" screens + HDMI Socket

## OPTIONAL

- ARS (Air Refreshing System) to cool the booth
- Access to Online usage statistics
- Single use hygienic sheet roll
- Basket for used sheets
- Touch pad with sophrology program - Choice of lights and sound environment.
- Logo embossment (your own logo!)

# CONCEPT PODS

Dimensions: Various options



Concepts for Schools,  
Airports, Healthcare  
providers and more.

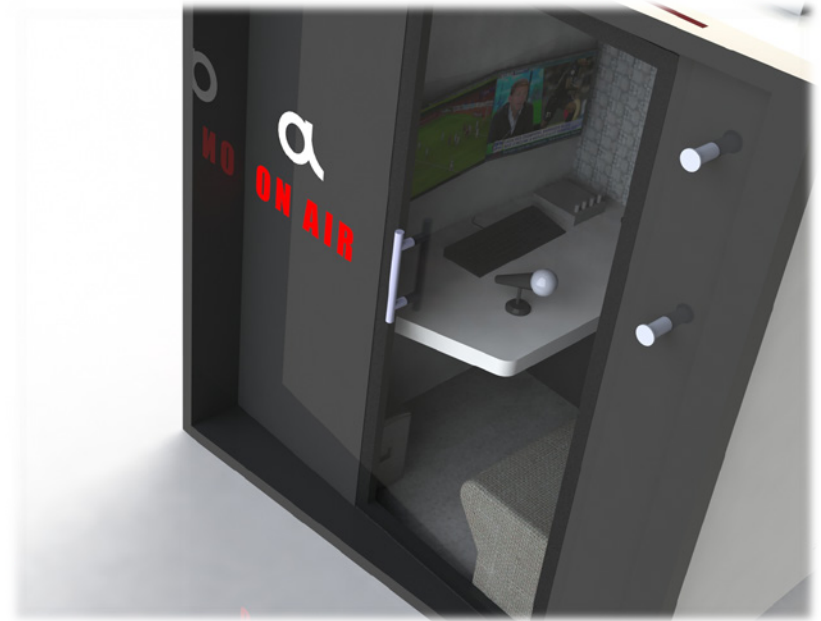
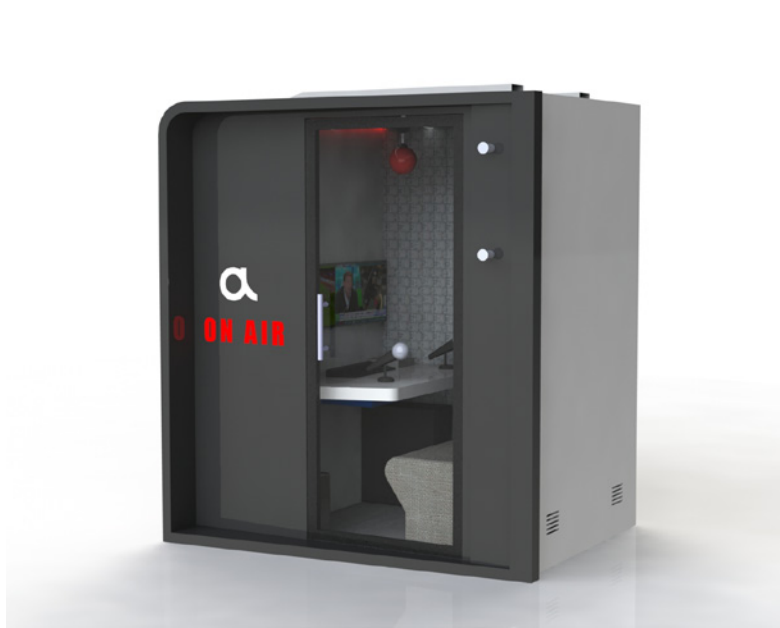

# CUSTOM PROJECTS







1255 South Park Dr,  
Kernersville, NC 27284 USA  
Tel. 336-996-7774  
Fax 336-996-1812  
E-mail: [info@petermeier.com](mailto:info@petermeier.com)

[www.petermeier.com](http://www.petermeier.com)