



**F70**

***SALICE***



# Index

Slide installation	page 5
Technical information	page 8
Part number composition	page 10

---



## F70 CLIPS / LOCKING DEVICES

Standard mount - 6 way adjustable	page 12
Vertical mount - 6 way adjustable	page 13
Narrow drawer clip	page 14
Adjustments	page 16

---



<b>F70 SMOVE</b>	Soft close for 12 mm (1/2") to 16 mm (5/8") drawer material thickness	page 22
------------------	--------------------------------------------------------------------------	---------

---



<b>F70 PUSH</b>	Push opening system for 12 mm (1/2") to 16 mm (5/8") drawer material thickness	page 26
-----------------	-----------------------------------------------------------------------------------	---------

---



## ACCESSORIES

F70 Push synchronizer	page 30
Steel sockets	page 33
Drilling templates for drawers	page 34
Tilt adjustment lever	page 37
Side spacer	page 37
Screws and pozi driver	page 38

## F70

F70 is a new generation of heavy duty drawer slides. Rated at 170 Lbs Static load capacity and 150 Lbs Dynamic load capacity\*, they are suitable for all drawer opening applications. As is customary with all Salice products, F70 is available in either Soft Close or Push to Open versions:

- full extension with a synchronized mechanism
- with Smove decelerated closing (see page 22)
- with Push opening in handle-less furniture (see page 26)

## Smove

Soft Close feature fully integrated in the runner system.



Push to Open feature fully integrated in the runner system.



\* Per Ansi BHMA A156.9-2020 Grade 1 standard in a frameless cabinet using a 21" runner length and a recommended number of fixing screws.



# Slide installation

## Mounting full-extension runner on cabinet side

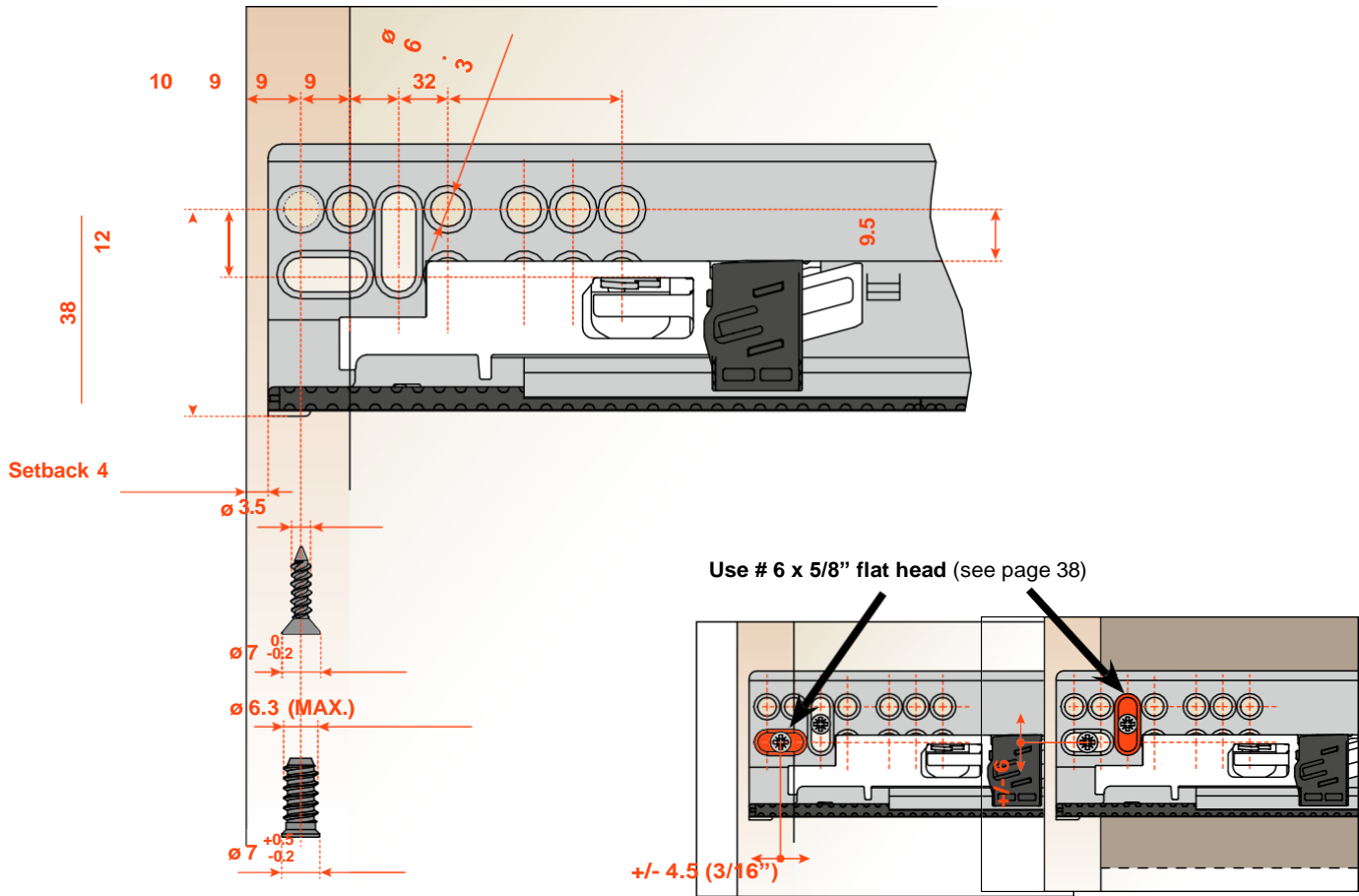

See screws, page 38.

Elongated holes are for  $\pm 4.5$  (3/16") depth adjustment only. Additional screws must be used to secure the runner to the cabinet.

Elongated holes are for  $\pm 6$  (1/4") vertical adjustment only. Additional screws must be used to secure the runner to the cabinet. Only with frameless application or face frame application with filler.

## Drawer slide assembly Face frame application with metal socket

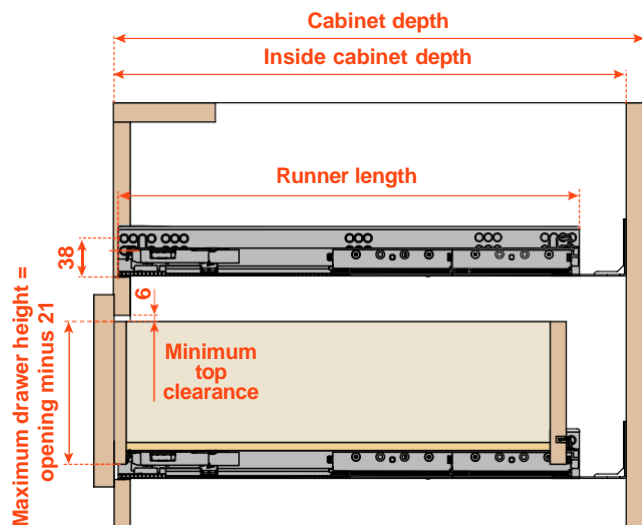

## Drawer slide assembly Face frame application with filler behind frame Frameless application

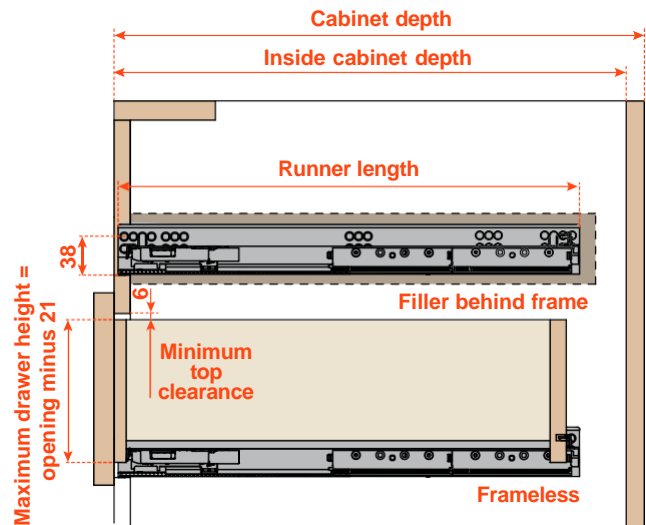

**Drilling patterns - Standard face frame cabinet member**

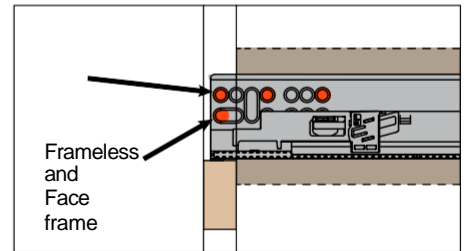
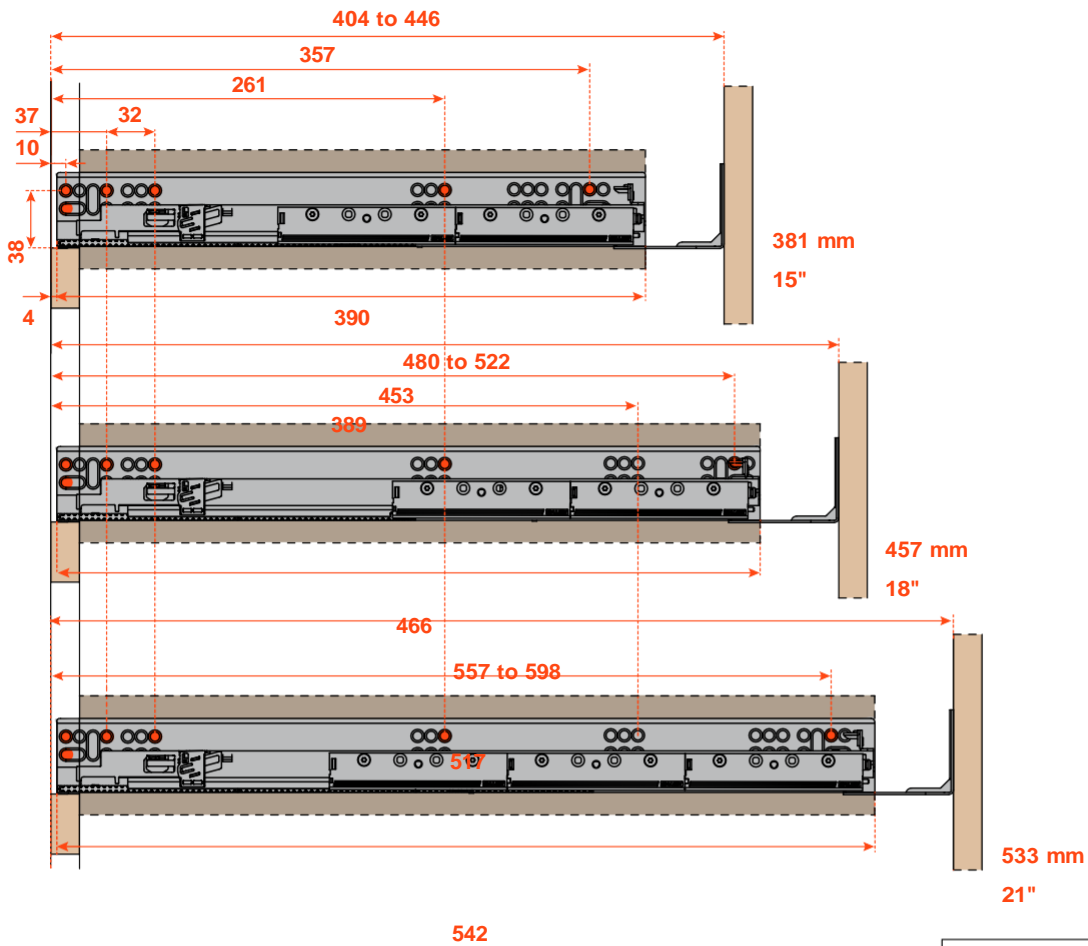

Face frame only

Note: orange dots indicate fixing screw locations and quantity to meet load ratings.

Mounting to the cabinet side - Runner lengths 381, 457 and 533 mm

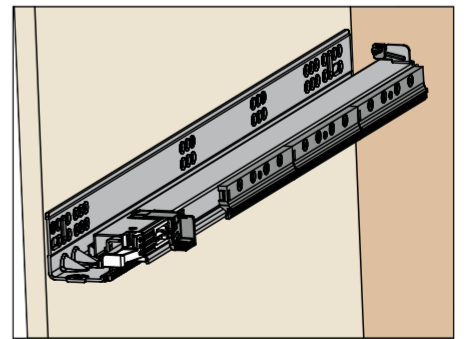
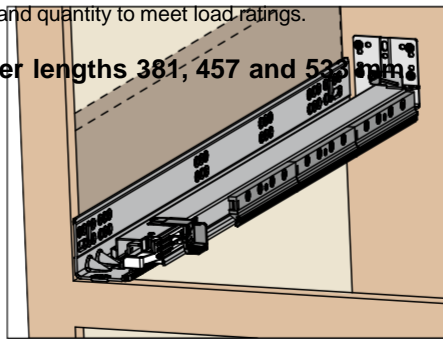
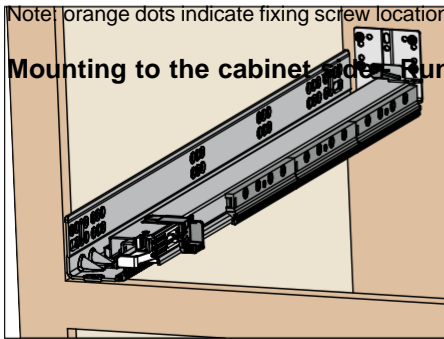

Face frame application with metal socket

Face frame application with filler behind frame

Sockets and brackets can be used for the correct alignment of the runners before fixing to the cabinet side.

**Frameless application**





## Drilling patterns - Short version cabinet member

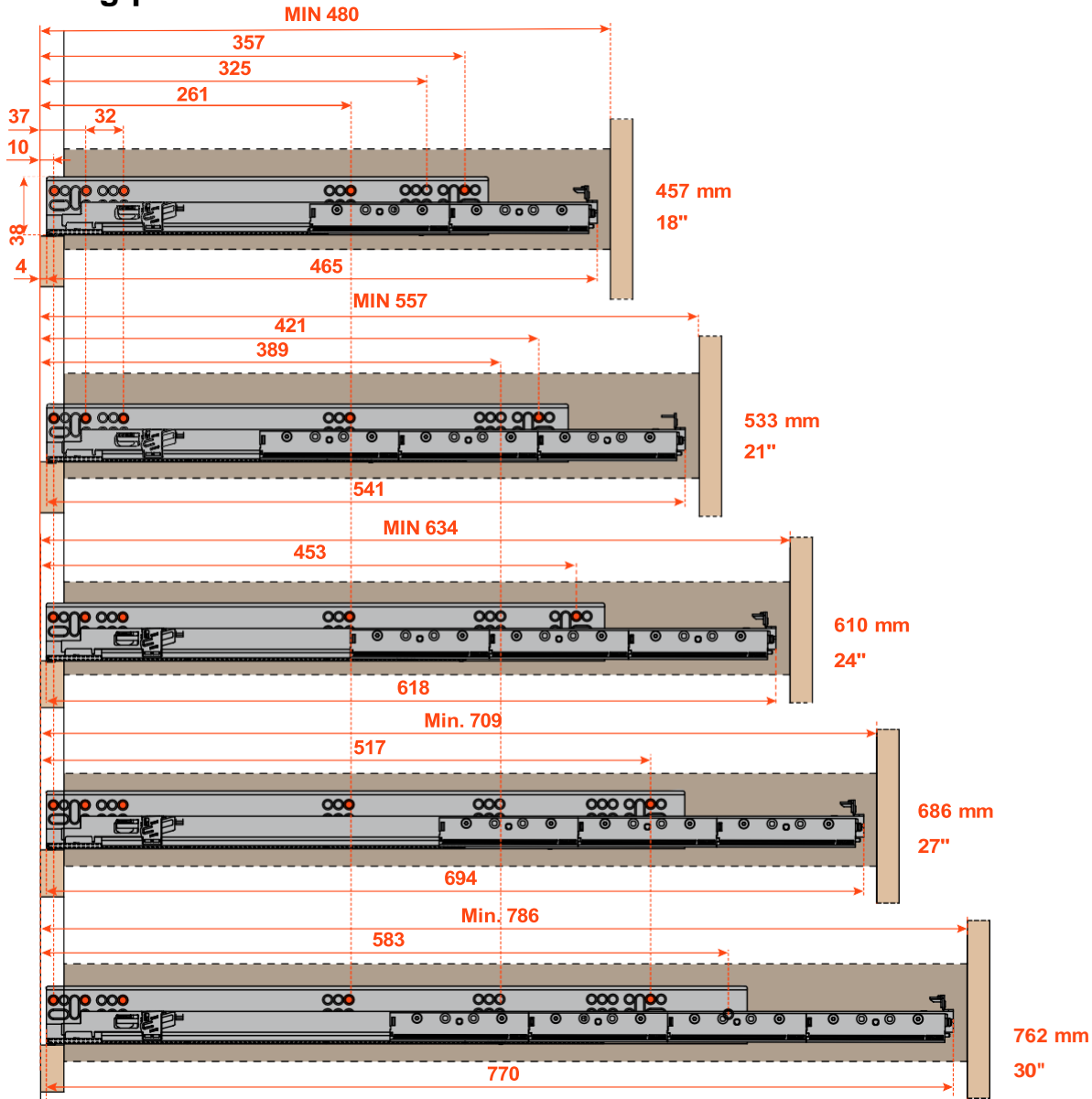

Note: orange dots indicate fixing screw locations and quantity to meet load ratings.

### Mounting to the cabinet side - Runner lengths 457, 533, 610, 686 and 762 mm

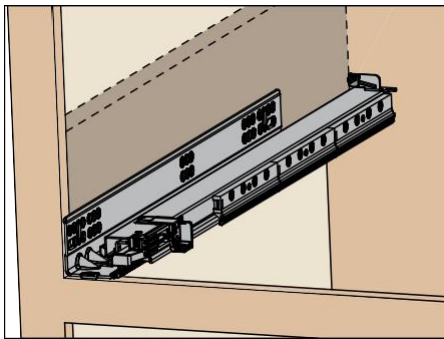

Face frame application with filler behind frame

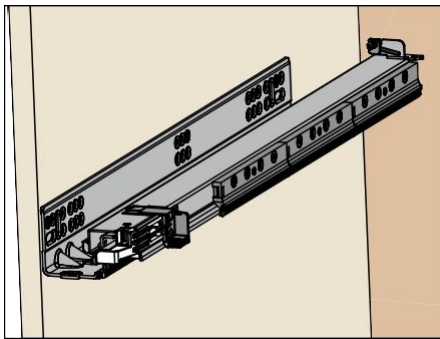

Frameless application

## Technical information - Drawer settings

Use of at least 4 fixing screws to the side is highly recommended. For these runner lengths rear brackets and sockets cannot be used. Cabinet sides must be blocked. On longer lengths load capacity may vary.

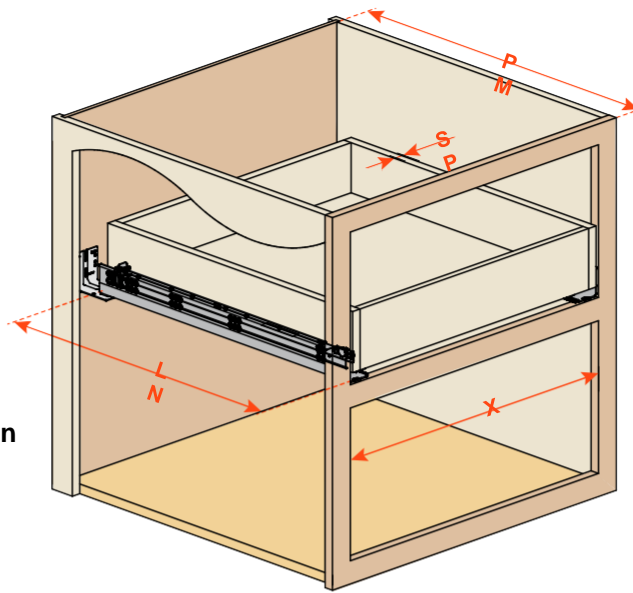

**Face frame application  
with metal socket**

**DRAWER SETTING  
ABBREVIATIONS:**

- SP** = Drawer side thickness
- LN** = Nominal runner length
- PM** = Cabinet depth
- X** = Cabinet internal width
- LC** = Drawer length

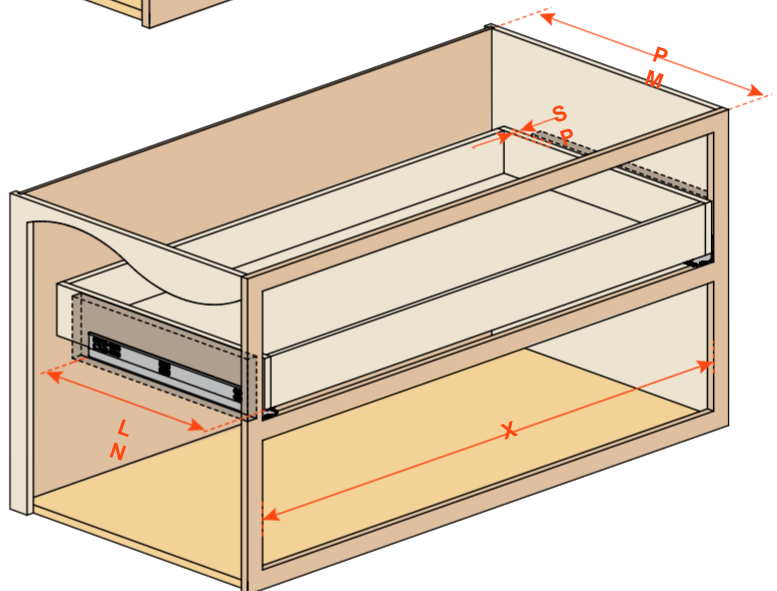

**Face frame application  
with filler behind frame**

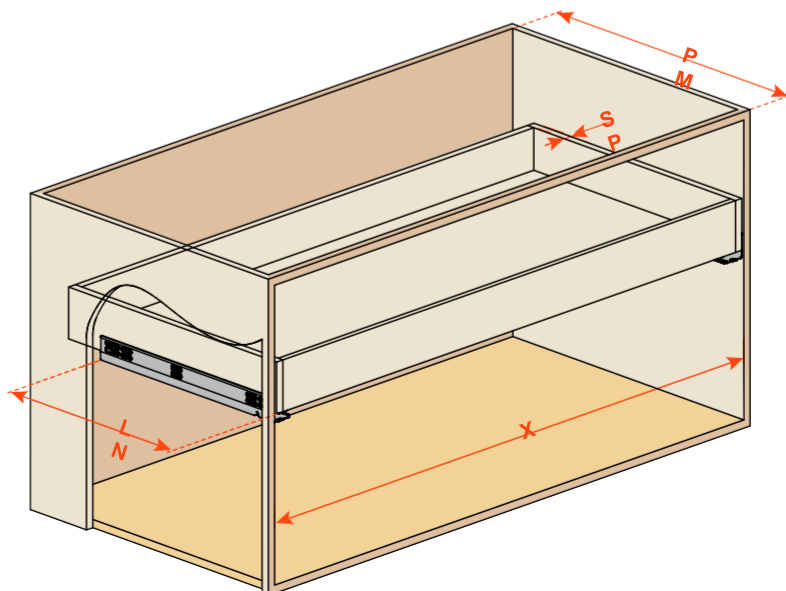

**Frameless application**

## Technical information drilling

Full-extension runner for 12 mm (1/2") to 16 mm (5/8") drawer material

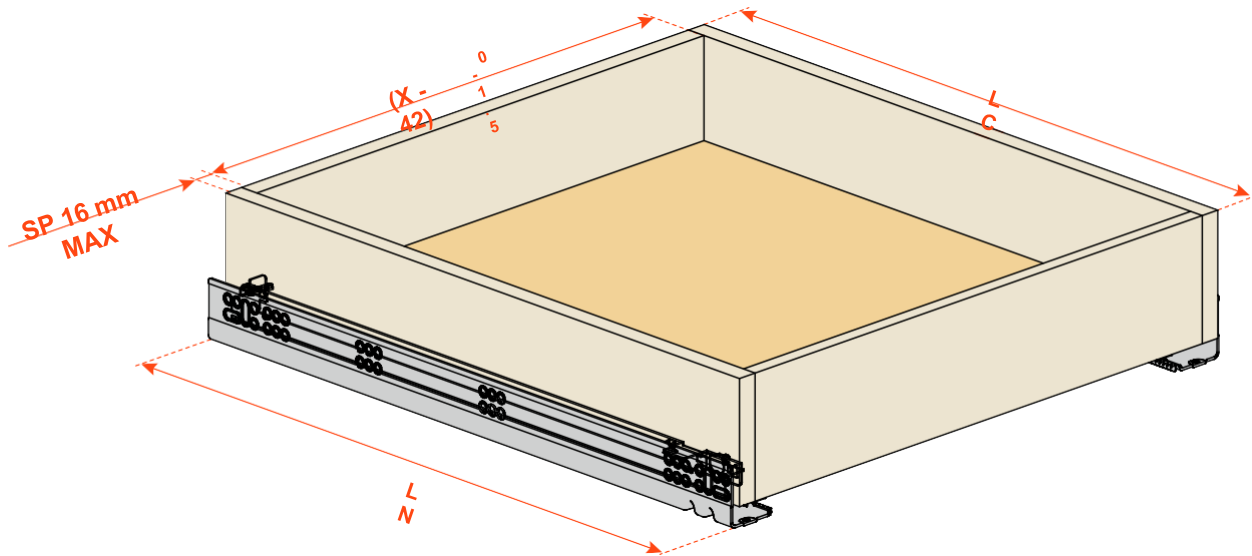

### Rear hook



Use **SGD704UGXA** drilling template for rear hook, see page 34.

### Drawer back preparation

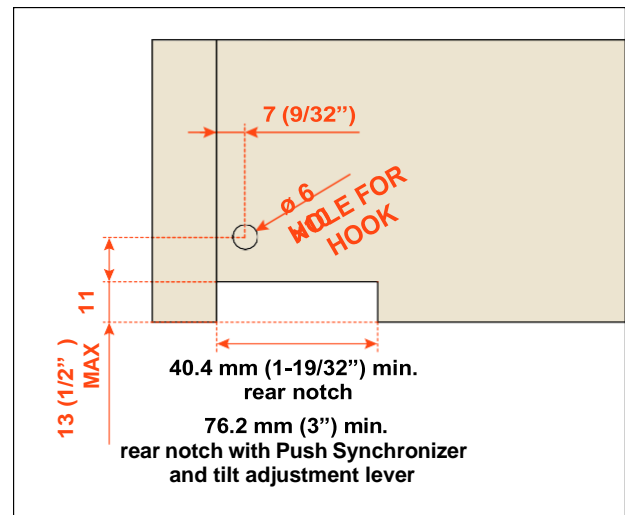

F70 Push Synchronizer, see page 30.

AGLRXX3F tilt adjustment lever, see page 37.



**Part number composition - Ordering chart**

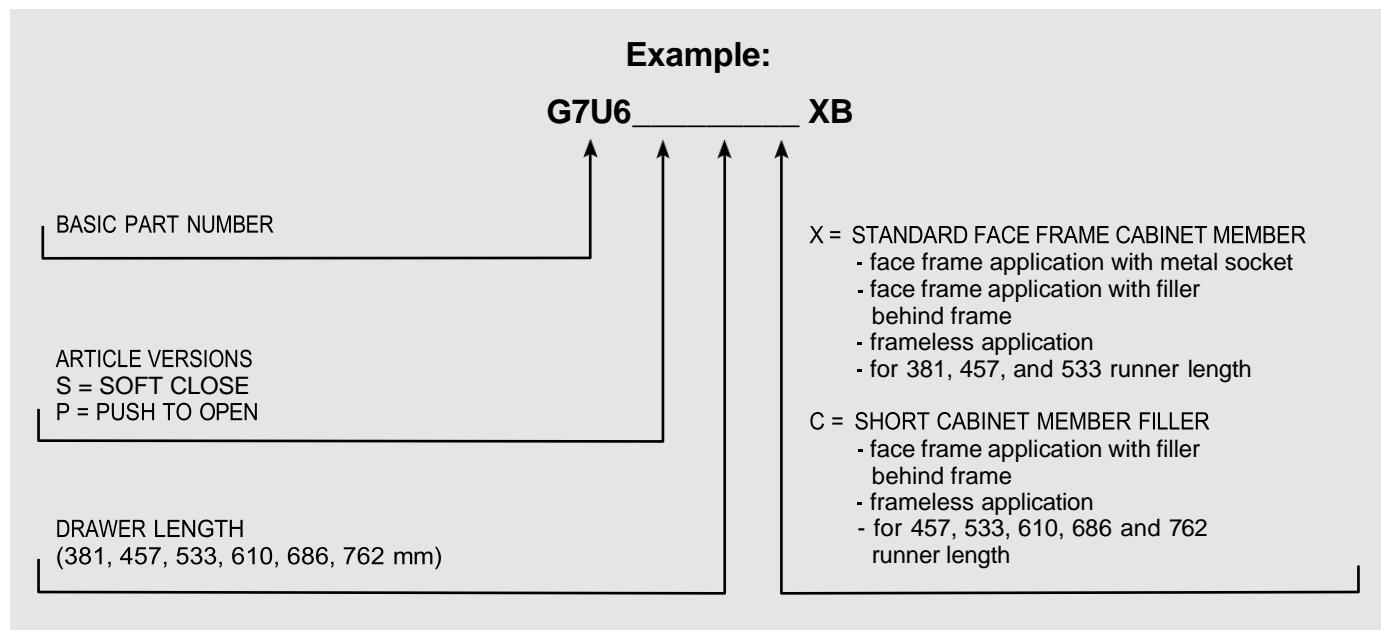

**Industrial packaging**

SMOVE	LENGTH	BOX	PALLET
G7U6S381XXB	381 mm	6 pcs right / 6 pcs left	384 pcs right / 384 pcs left
G7U6S457XXB	457 mm	6 pcs right / 6 pcs left	384 pcs right / 384 pcs left
G7U6S457CXB	457 mm	6 pcs right / 6 pcs left	384 pcs right / 384 pcs left
G7U6S533XXB	533 mm	6 pcs right / 6 pcs left	384 pcs right / 384 pcs left
G7U6S533CXB	533 mm	6 pcs right / 6 pcs left	384 pcs right / 384 pcs left
G7U6S610CXB	610 mm	4 pcs right / 4 pcs left	256 pcs right / 256 pcs left
G7U6S686CXB	686 mm	4 pcs right / 4 pcs left	256 pcs right / 256 pcs left
G7U6S762CXB	762 mm	4 pcs right / 4 pcs left	256 pcs right / 256 pcs left

PUSH	LENGTH	BOX	PALLET
G7U6P381XXB	381 mm	6 pcs right / 6 pcs left	384 pcs right / 384 pcs left
G7U6P457XXB	457 mm	6 pcs right / 6 pcs left	384 pcs right / 384 pcs left
G7U6P457CXB	457 mm	6 pcs right / 6 pcs left	384 pcs right / 384 pcs left
G7U6P533XXB	533 mm	6 pcs right / 6 pcs left	384 pcs right / 384 pcs left
G7U6P533CXB	533 mm	6 pcs right / 6 pcs left	384 pcs right / 384 pcs left
G7U6P610CXB	610 mm	4 pcs right / 4 pcs left	256 pcs right / 256 pcs left
G7U6P686CXB	686 mm	4 pcs right / 4 pcs left	256 pcs right / 256 pcs left
G7U6P762CXB	762 mm	4 pcs right / 4 pcs left	256 pcs right / 256 pcs left

CLIPS - LOCKING DEVICES	BOX	PALLET
AFCGX3B	100 pcs right / 100 pcs left	2400 pcs right / 2400 pcs left
AFCGX43B	100 pcs right / 100 pcs left	2400 pcs right / 2400 pcs left
AFCEX43B	100 pcs right / 100 pcs left	2400 pcs right / 2400 pcs left

SOCKETS	BOX	PALLET
AGSK7C5B	100 pcs	4000 pcs
AGSK7R5B	100 pcs	4000 pcs





## **F70 Clips - Locking devices**

## F70 Locking devices - Standard mount - side and depth adjustments

- Dual steel/plastic construction
- For all F70 runner versions
- Tool free lateral and depth adjustments
- Pre-drilling recommended  $\varnothing$  2.5 mm (3/32")

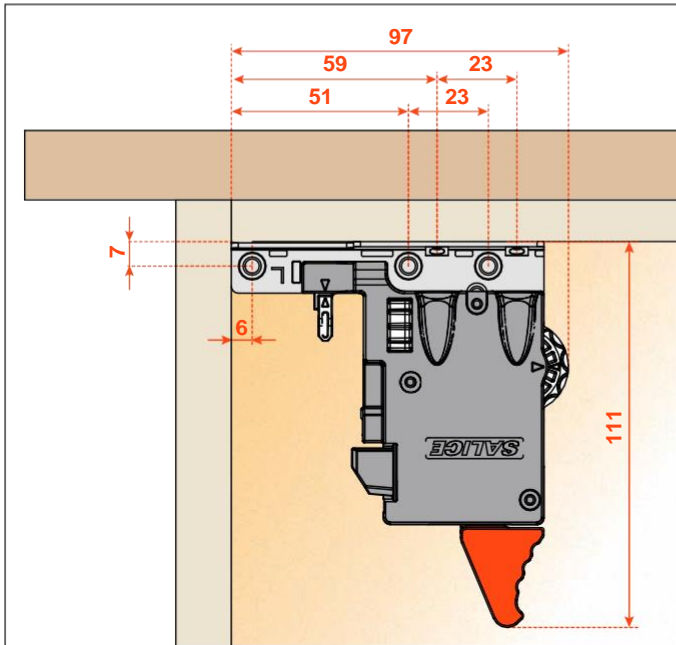

**AFCGXX3B**

PACKAGING  
2 boxes = 100 pcs. LEFT and RIGHT

### Assembly to the bottom

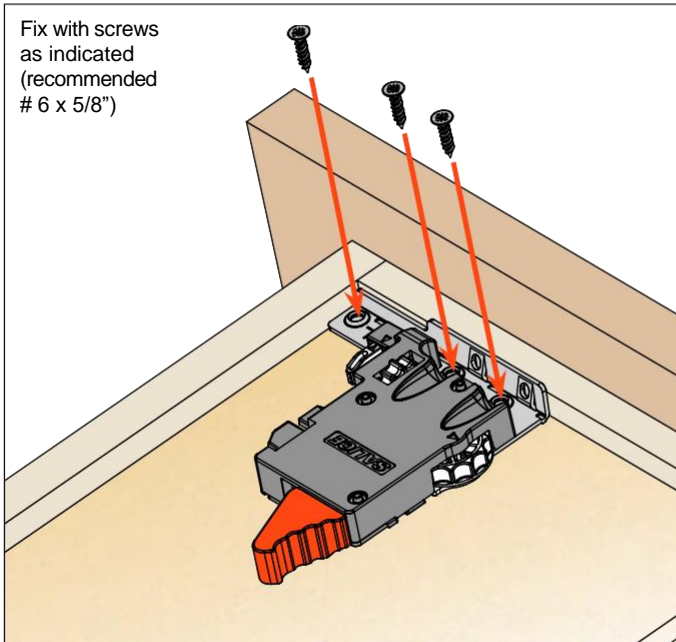

### Assembly to the sub-front drawer member

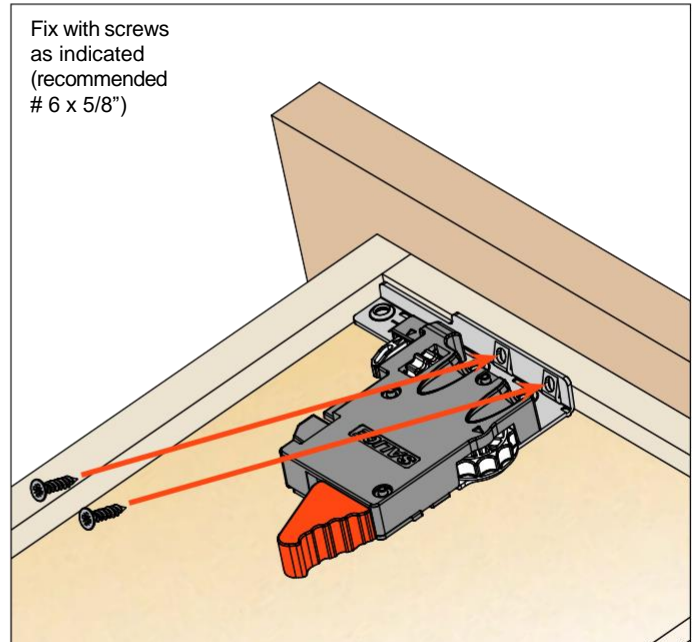

Use **drilling template** for accurate installation of the clips, see page 35.

## F70 Locking devices - Vertical mount - side and depth adjustments

- Dual steel/plastic construction
- For all F70 runner versions
- Tool free lateral and depth adjustments
- Overhang must be 13 mm (1/2")
- Pre-drilling recommended  $\varnothing$  2.5 mm (3/32")

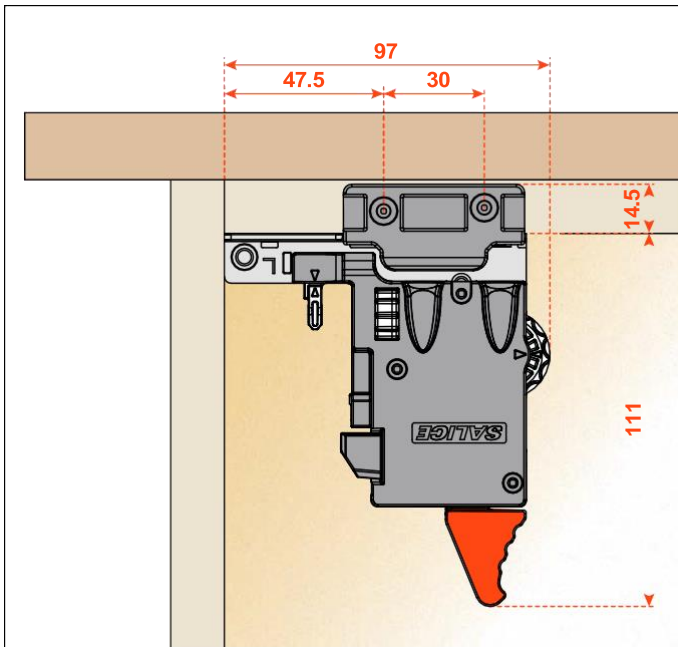

### AFCGX43B

PACKAGING  
2 boxes = 100 pcs. LEFT and RIGHT

## Assembly to the sub-front drawer member

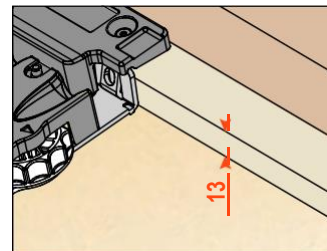
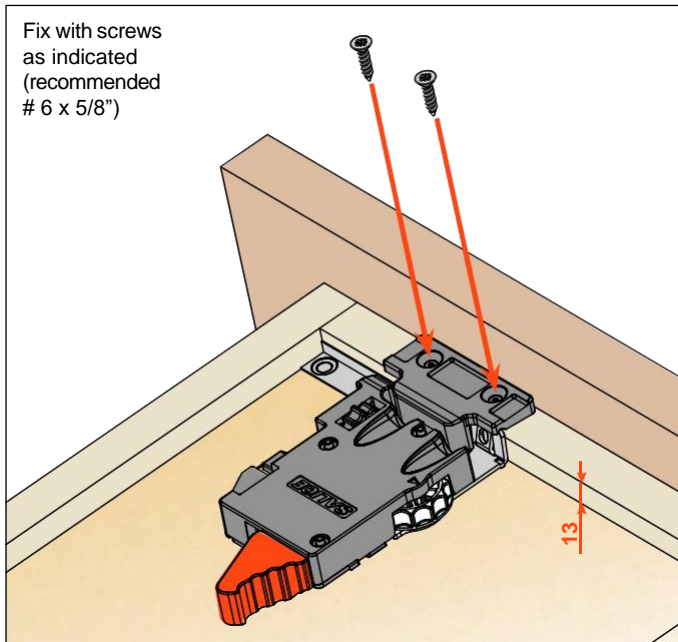

Use **drilling template** for accurate installation of the clips, see page 35.

Overhang must be 13 mm (1/2").

## F70 Locking devices - Narrow drawer clip

- For use with narrow drawers
- For all F70 runner versions
- Overhang must be 13 mm (1/2")

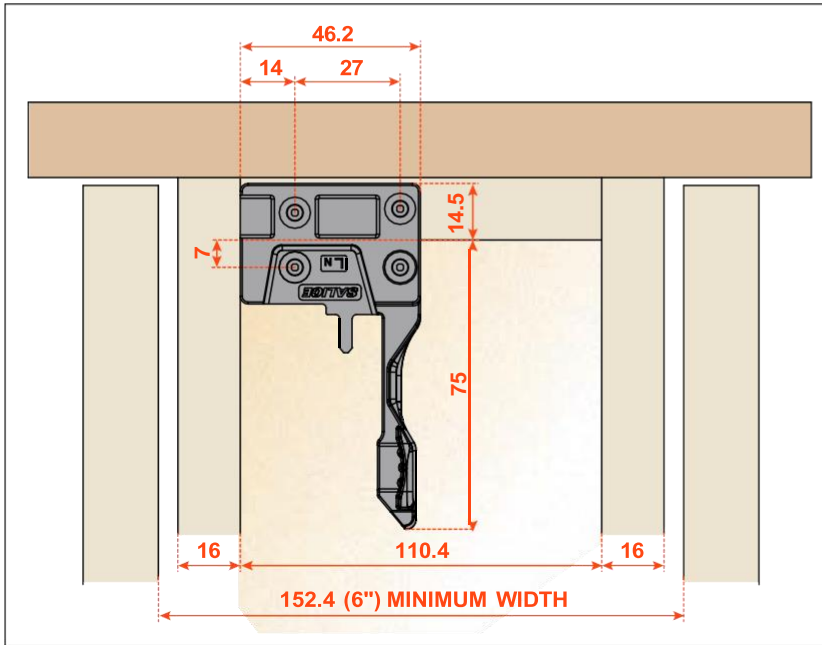

**AFCEX43B**

PACKAGING  
2 boxes = 100 pcs. LEFT and RIGHT

### Assembly to the bottom

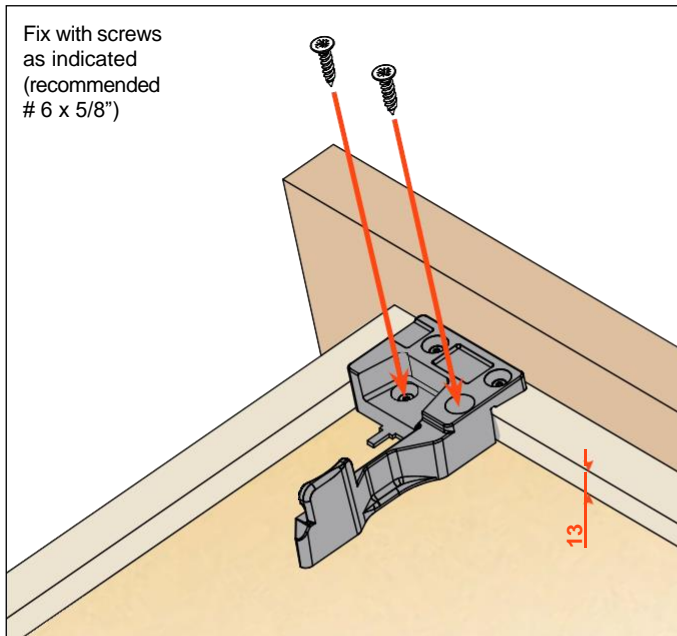

Use **drilling template** for accurate installation of the clips, see page 36.

### Assembly under the sub-front drawer member

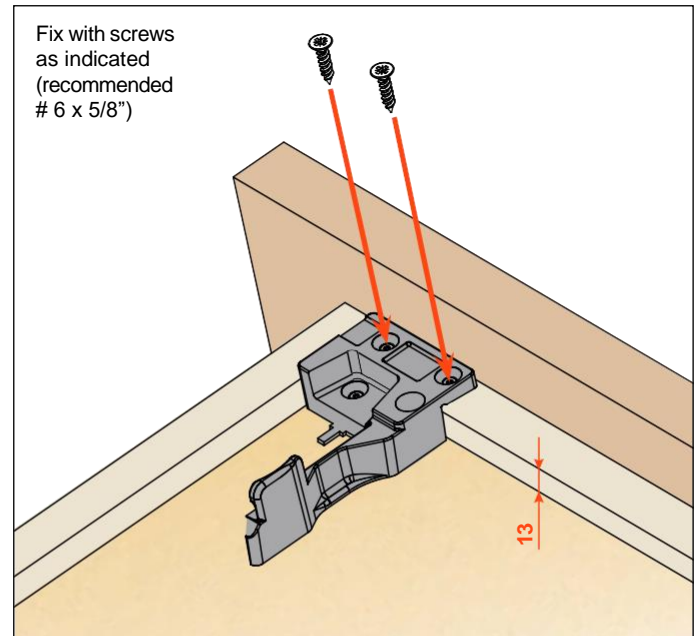

Use **drilling template** for accurate installation of the clips, see page 36.

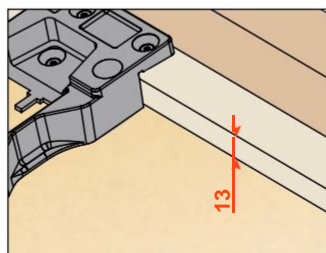

Overhang must be 13 mm (1/2").

## Drawer opening devices - Narrow drawer clip

### Standard and vertical mount

Position hands under the front of the drawer and press on the orange levers, as indicated in the drawing, sliding the drawer out of the cabinet.

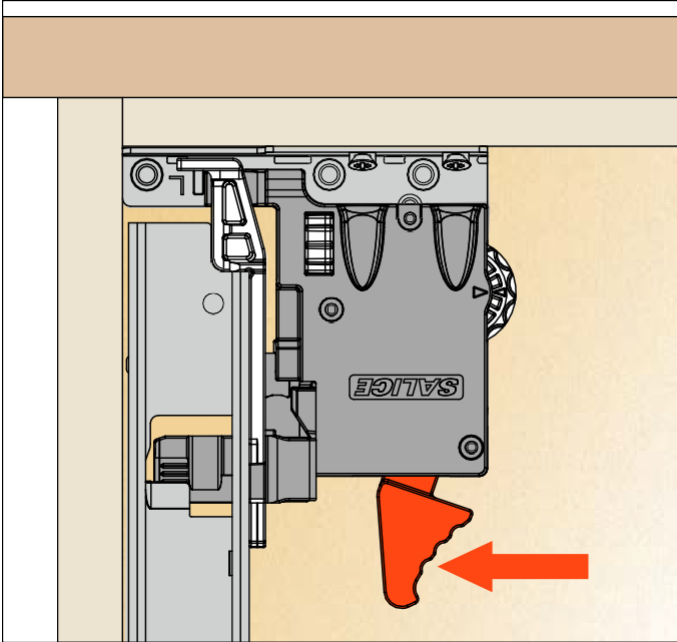

---

### Narrow drawer clip

Position hands under the front of the drawer and press on the black levers, as indicated in the drawing, sliding the drawer out of the cabinet.

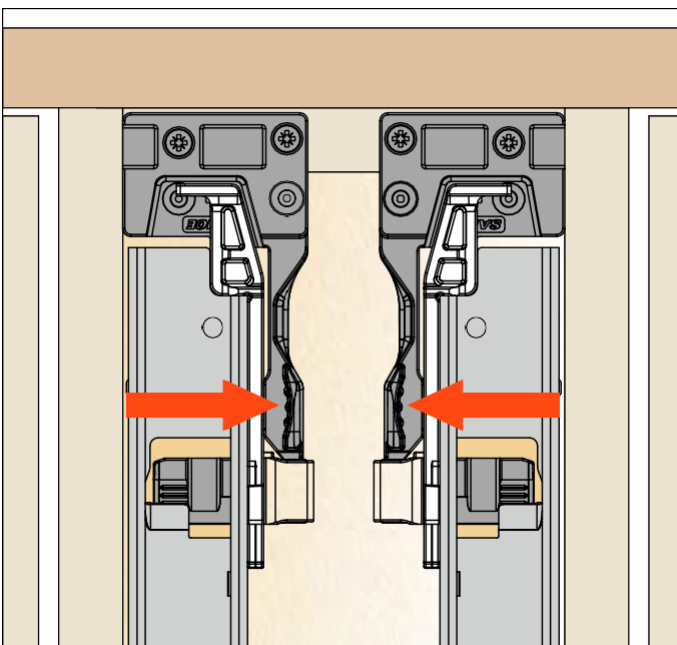





## Side adjustment +/- 1.5 mm

Rotate the white wheel (see drawing) towards the front of the drawer to adjust left.  
This operation is tool free.

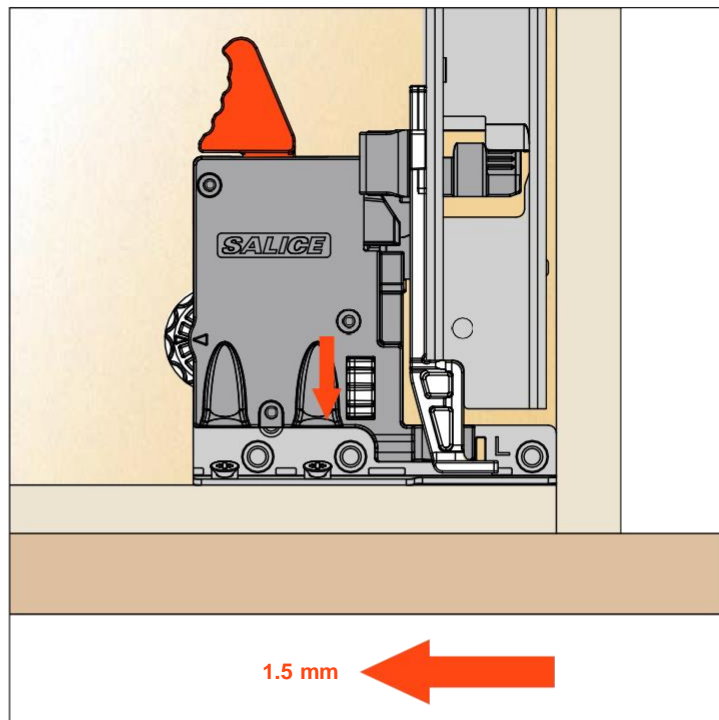
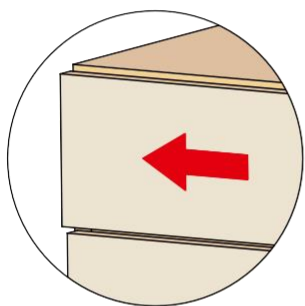
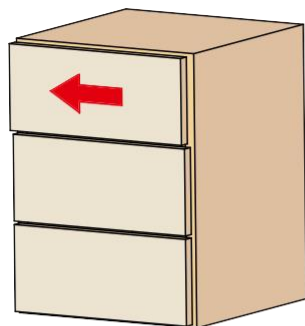

Rotate the white wheel (see drawing) towards the back of the drawer to adjust right.  
This operation is tool free.

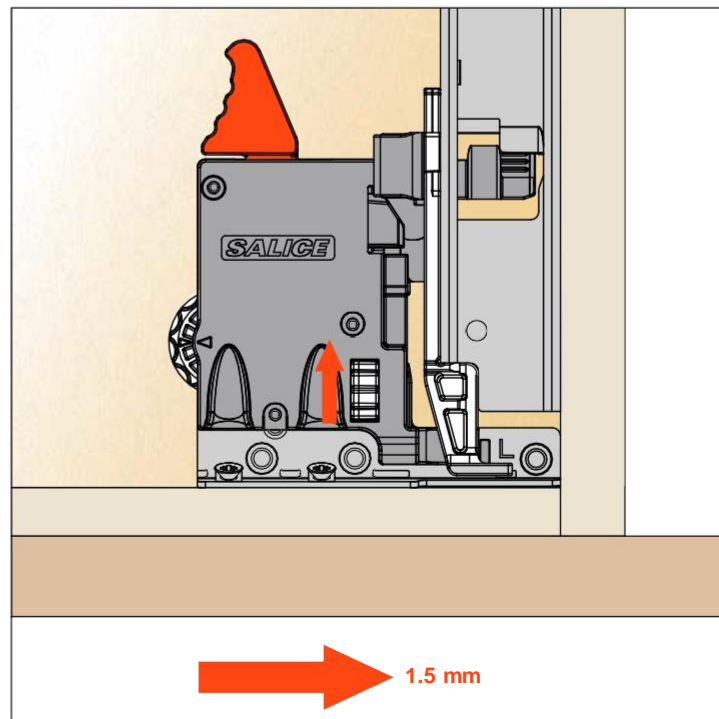
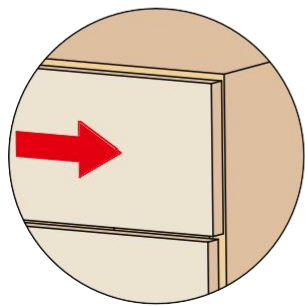
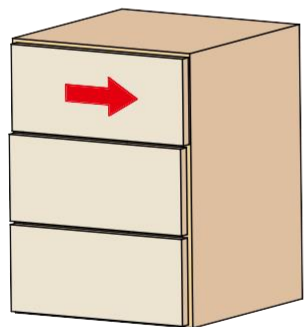

For side adjustment, it is recommended that both the adjusters on the clips are in the same direction, in order to maintain the correct alignment and function of the runners.

## Depth adjustment +/- 3 mm

Rotate the white wheel (see drawing) towards the outside of the drawer to increase the gap between the front and the side. This operation is tool free.

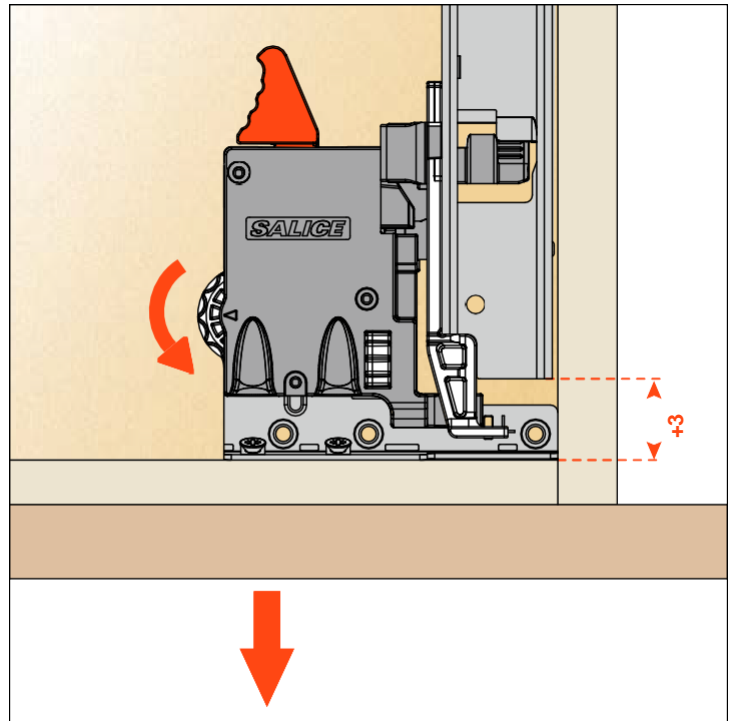
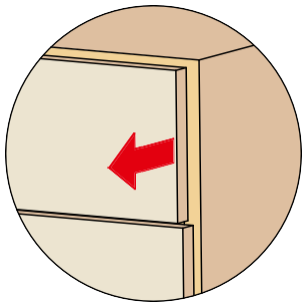
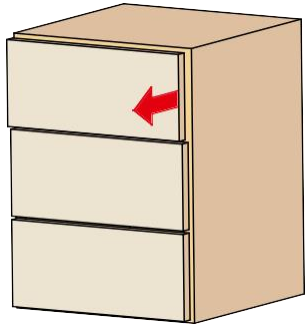

Rotate the white wheel (see drawing) towards the inside of the drawer to reduce the gap between the front and the side. This operation is tool free.

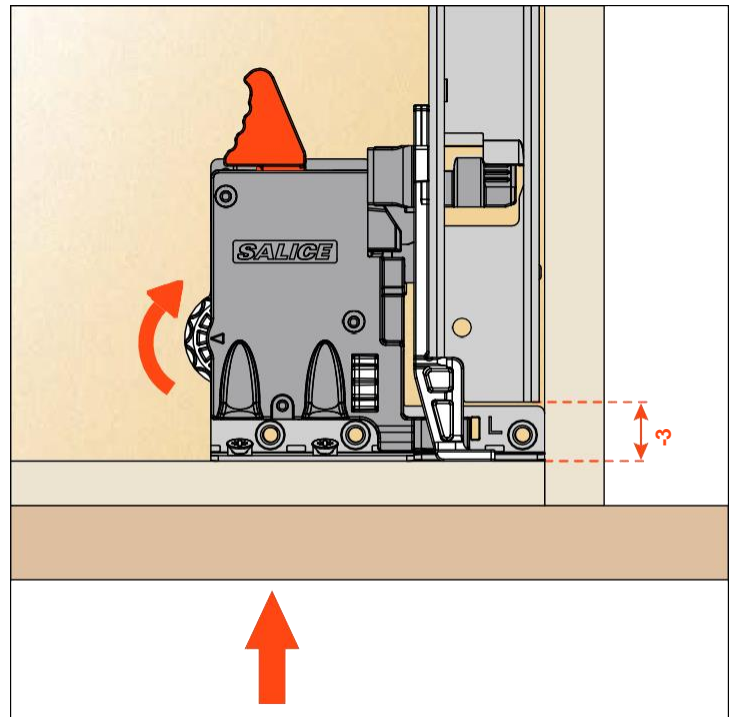
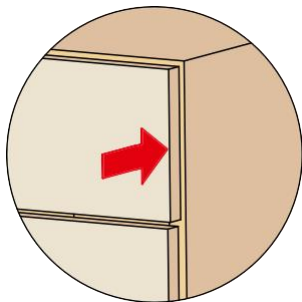
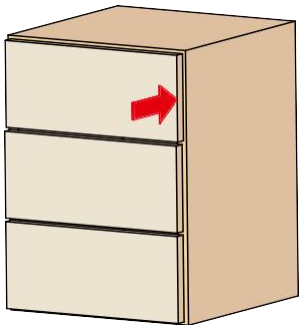

## Height adjustment + 2.5 mm

Press the lever towards the back of the drawer to achieve the height adjustment.  
This operation is tool free.

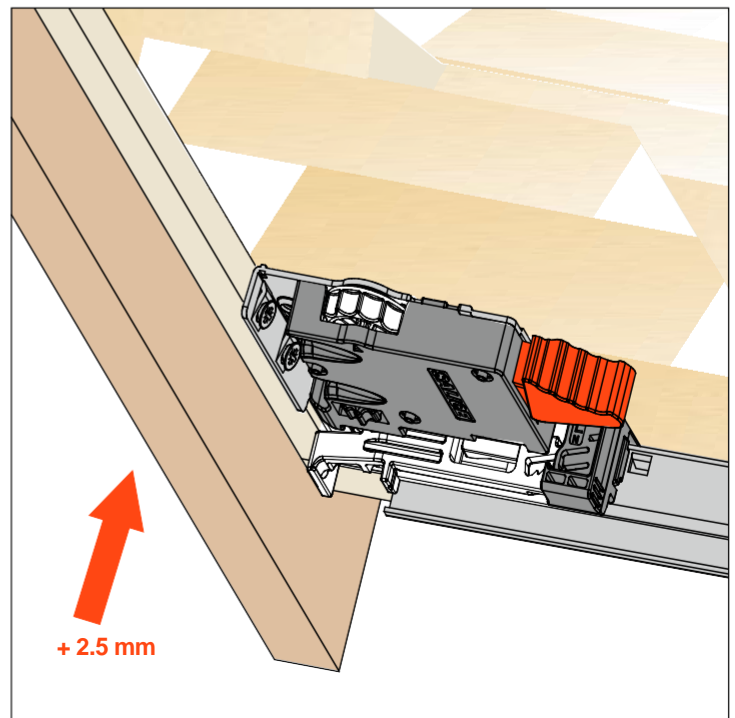
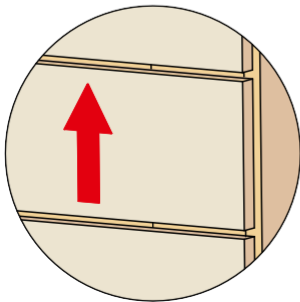
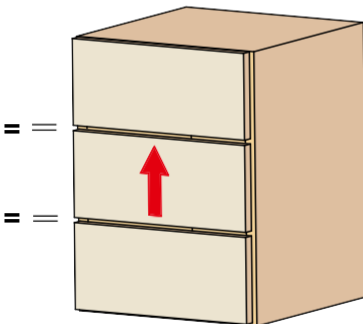
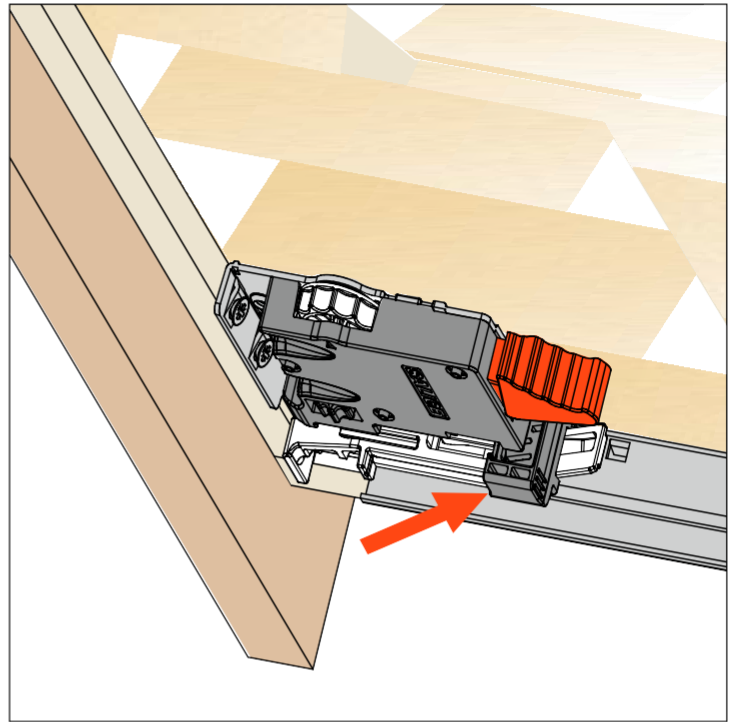
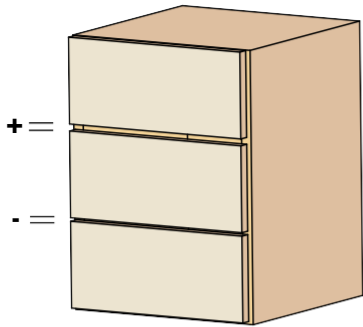

## Assembly of tilt adjustment levers (optional)

Pull out the drawer and remove the plastic insert, both right and left.

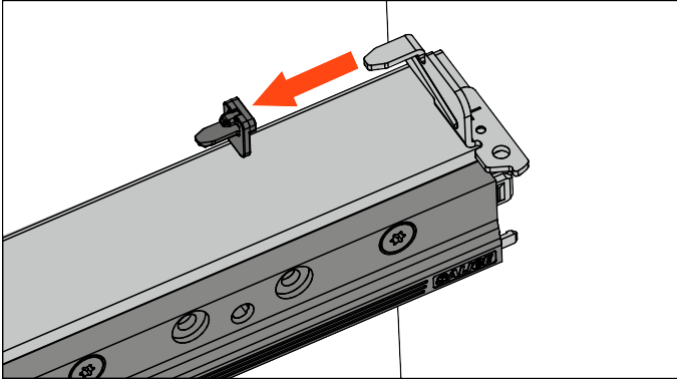

Insert the tilt adjustment levers, both right and left.

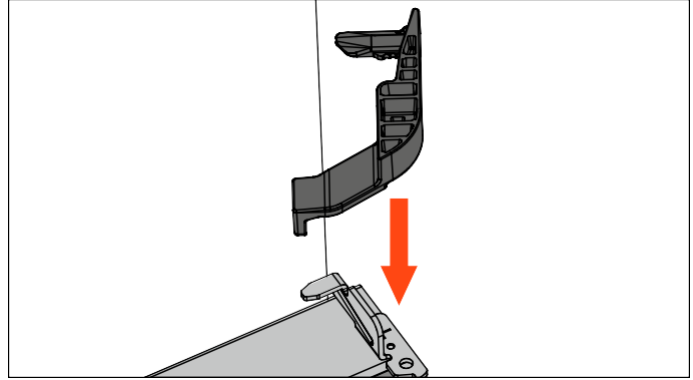

Rotate the lever to adjust.

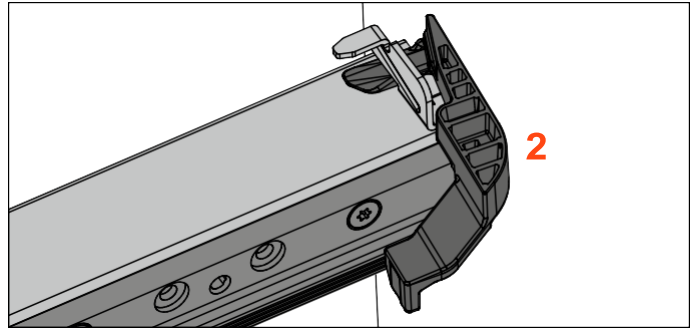
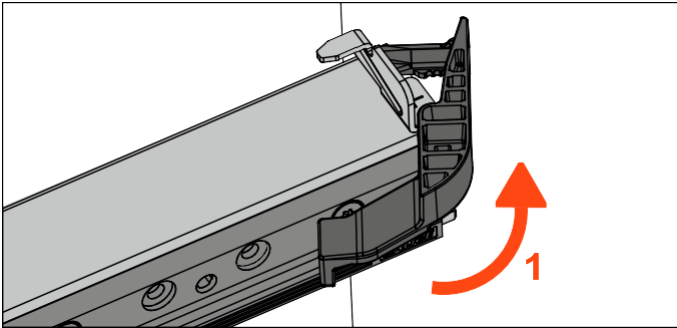

## Tilt adjustment

Open the drawer (1) and press the lever towards the back of the cabinet (2) to achieve the adjustment.

Maximum 3 mm (1/8") rise of drawer back (tool free).

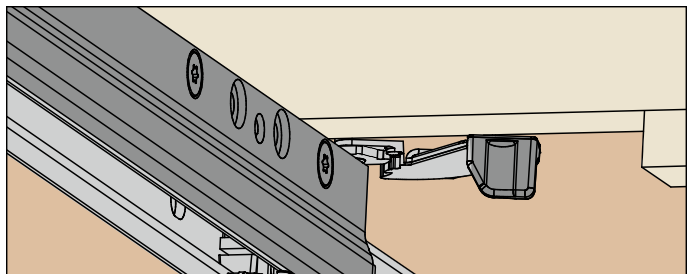
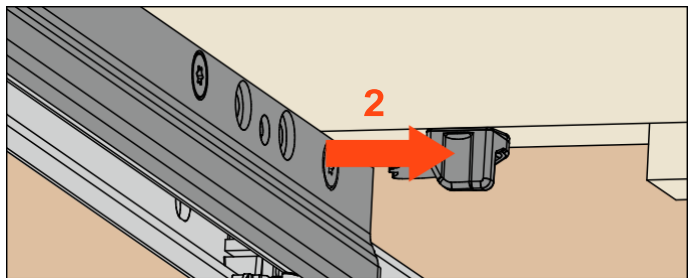
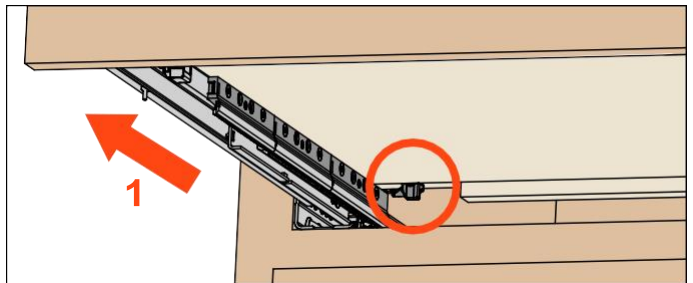
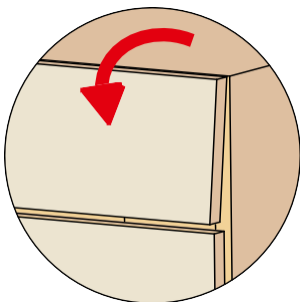
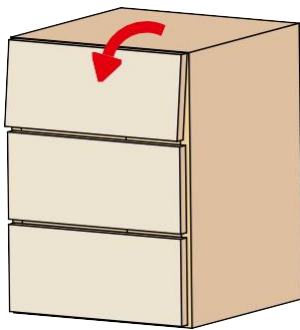

Drawer back preparation, see page 9.  
AGLRXX3F tilt adjustment lever, see page 37.







# F70 Smove

**F70 Smove - Full extension runner for 12 mm (1/2") to 16 mm (5/8") drawer material**



**SMOVE: SOFT CLOSE MECHANISM FULLY INTEGRATED INTO THE DRAWER RUNNER**

**Product features**

- 170 Lbs Static load capacity
- Full extension with a synchronized mechanism
- Available in 15" to 30" length
- Enhanced smooth soft closing action
- Elongated holes for depth and height adjustment
- Adjustable clips allow for easy drawer insertion and removal; special clip for narrow drawers
- Tool free height adjustments + 2.5 mm
- Tool free depth adjustments +/- 3 mm
- Tool free side adjustments +/- 1.5 mm
- Optional tool free tilt adjustment +3 mm
- 12 mm (1/2") to 16 mm (5/8") drawer thickness
- Compatible with Lineabox drawers
- Finish: bright zinc-plated
- 100% Made in Italy

**Dimensions**

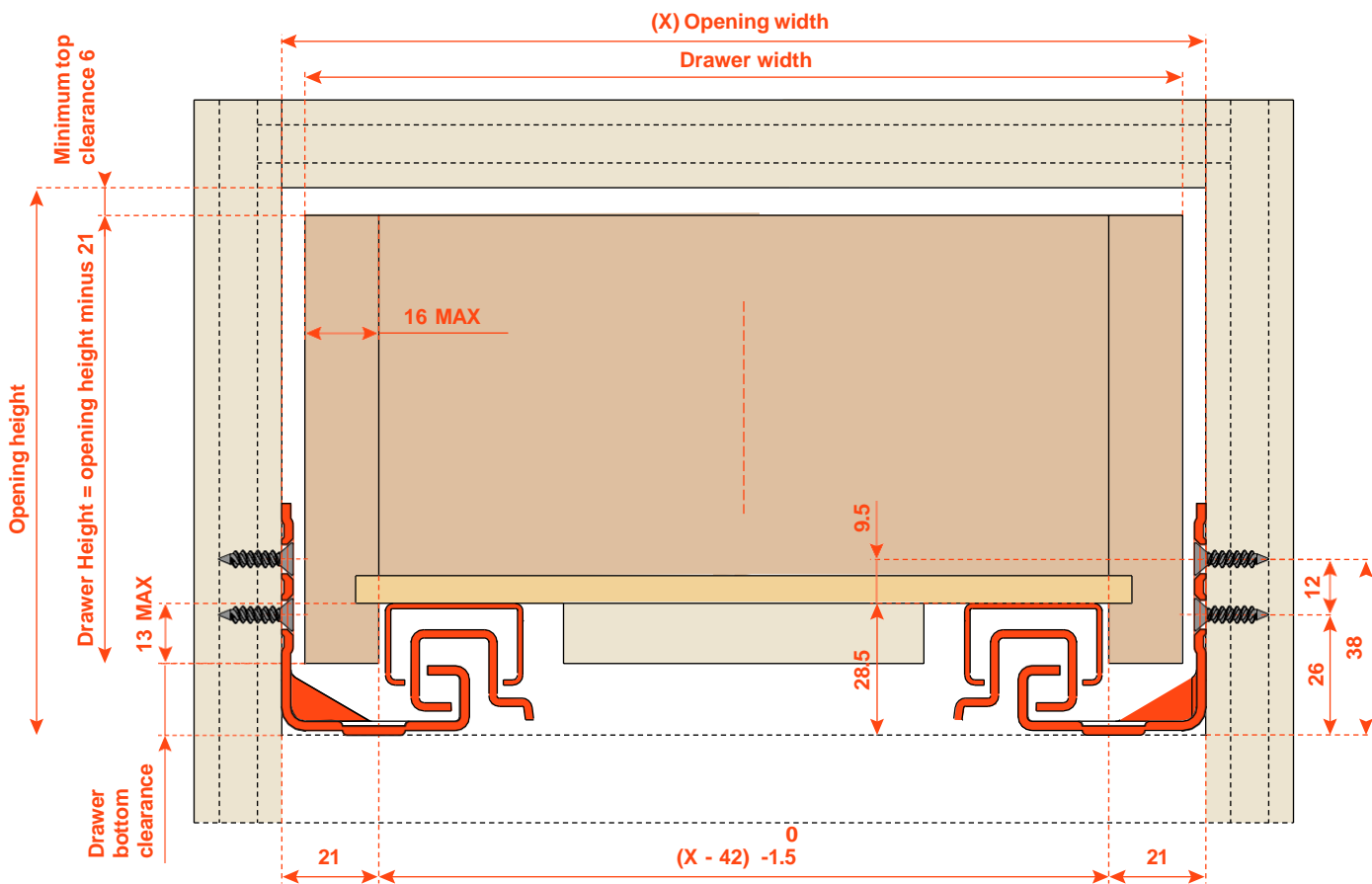

**CALCULATION FORMULA FOR OUTSIDE DRAWER WIDTH**

For drawer side thickness of	16 mm (5/8")	15 mm (19/32")	14 mm (9/16")	13 mm (1/2")	12 mm (15/32")
Deduct from inside cabinet width	10 mm (3/8")	12 mm (7/16")	14 mm (9/16")	16 mm (5/8")	18 mm (21/32")

Example: For a 15" inside cabinet width and a 5/8" thick drawer, subtract 3/8" from the inside width of 15" = 14-5/8" drawer width.

**Note:** Drawer side material thickness may vary. Make sure you take precise measurements when calculating outside drawer width using the table below. Inside drawer width must equal opening width minus 42 (1 21/32") for F70 runners to align and function optimally.

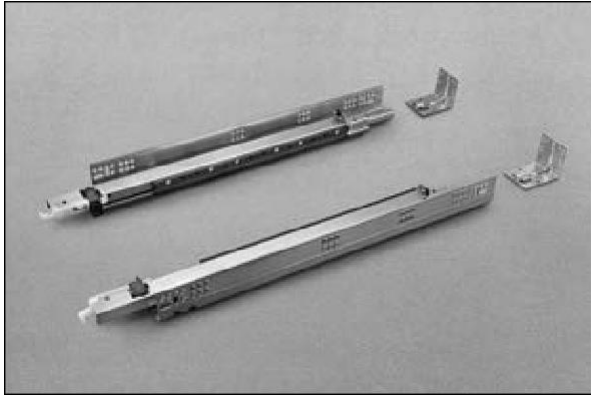

**381X - 457X - 533X**

Face frame assembly with metal socket  
Blocked out face frame cabinets or frameless.  
See page 6.

Please note that any load over 75 LBS requires a filler in addition to rear sockets.

**AFCGX3B**  
(right and left)



**AFCGX43B**  
(right and left)



**AFCEX43B**  
(right and left)

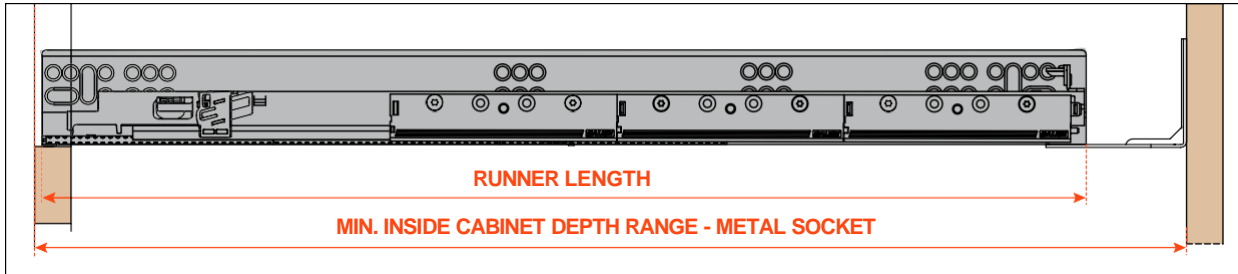

**AGSK7C5B**



**AGSK7R5B**



PART NUMBER	DRAWER LENGTH (LC)	RUNNER LENGTH (LN)	MINIMUM INSIDE CABINET DEPTH METAL SOCKET	MAXIMUM INSIDE CABINET DEPTH METAL SOCKET	MINIMUM INSIDE CABINET DEPTH
G7U6S381XXB	381 mm (15")	392 mm	402 mm	446 mm	401 mm
G7U6S457XXB	457 mm (18")	468 mm	480 mm	522 mm	477 mm
G7U6S533XXB	533 mm (21")	544 mm	557 mm	598 mm	554 mm

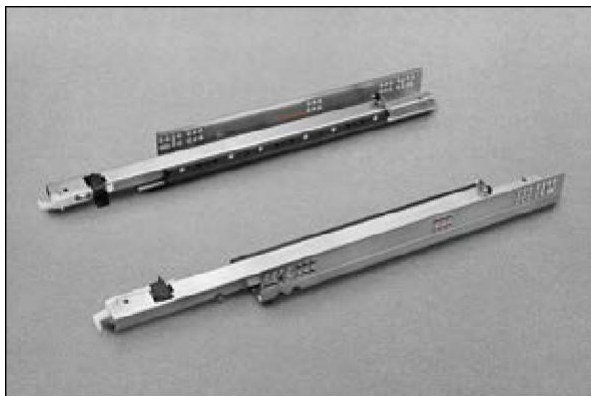

**457C - 533C - 610C - 686C - 762C**

Blocked out face frame cabinets or frameless.  
See page 7.

**AFCGX3B**  
(right and left)



**AFCGX43B**  
(right and left)



**AFCEX43B**  
(right and left)

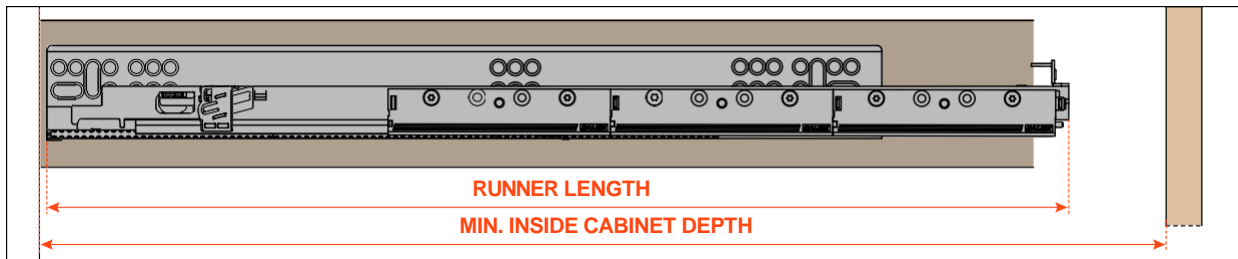

PART NUMBER	DRAWER LENGTH (LC)	RUNNER LENGTH (LN)	MINIMUM INSIDE CABINET DEPTH
G7U6S457CXB	457 mm (18")	468 mm	480 mm
G7U6S533CXB	533 mm (21")	544 mm	554 mm
G7U6S610CXB	610 mm (24")	621 mm	630 mm
G7U6S686CXB	686 mm (27")	697 mm	709 mm
G7U6S762CXB	762 mm (30")	773 mm	786 mm







# F70 Push

## F70 Push - Full extension runner for 16 mm (5/8") drawer material



**PUSH: THE OPENING SYSTEM FOR HANDLE-LESS DRAWERS IS FULLY INTEGRATED IN THE RUNNER. A SLIGHT PRESSURE OF THE DRAWER FRONT IS ENOUGH FOR THE DRAWER TO OPEN.**

**Product features**

- 170 Lbs Static load capacity
- Full extension with a synchronized mechanism
- Available in 15" to 30" length
- Integrated Push opening system
- Elongated holes for depth and height adjustment
- Adjustable clips allow for easy drawer insertion and removal, special clip for narrow drawers
- The drawer is latched when closed
- Frameless or blocked out face frame applications
- Tool free height adjustments + 2.5 mm
- Tool free depth adjustments +/- 3 mm
- Tool free side adjustments +/- 1.5 mm
- Optional:
  - tool free tilt adjustment +3 mm
  - F70 Push Synchronizer
- 12 mm (1/2") to 16 mm (5/8") drawer thickness
- Compatible with Lineabox drawers
- Finish: bright zinc-plated
- 100% Made in Italy

### Dimensions

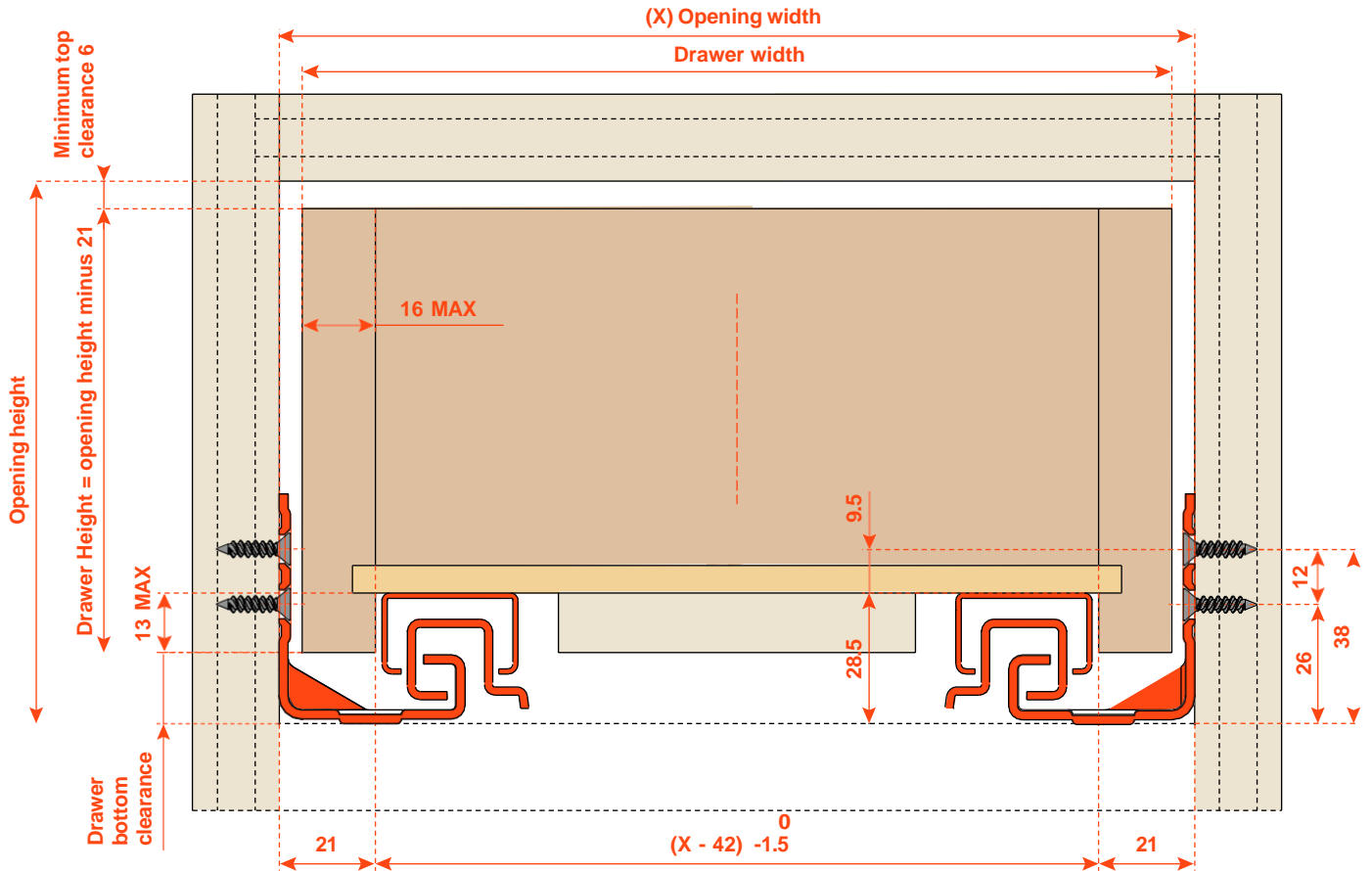

**CALCULATION FORMULA FOR OUTSIDE DRAWER WIDTH**

For drawer side thickness of	16 mm (5/8")	15 mm (19/32")	14 mm (9/16")	13 mm (1/2")	12 mm (15/32")
Deduct from inside cabinet width	10 mm (3/8")	12 mm (15/32")	14 mm (9/16")	16 mm (5/8")	18 mm (21/32")

Example: For a 15" inside cabinet width and a 5/8" thick drawer, subtract 3/8" from the inside width of 15" = 14-5/8" drawer width.

**Note:** Drawer side material thickness may vary. Make sure you take precise measurements when calculating outside drawer width using the table below. Inside drawer width must equal opening width minus 42 (1 21/32") for F70 runners to align and function optimally.



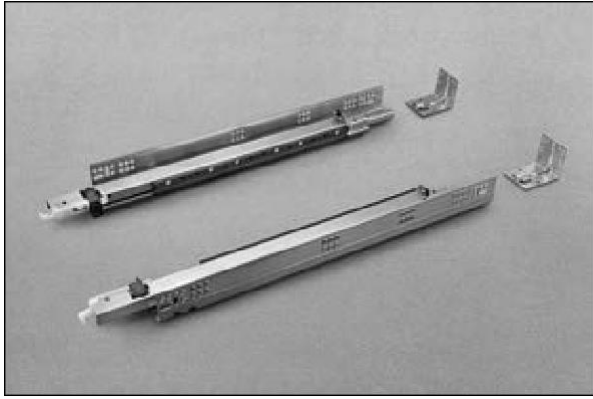

### 381X - 457X - 533X

Blocked out face frame cabinets or frameless

The socket can be used for the correct alignment of the runners before fixing to the cabinet side.  
See page 6.

**AFCGX3B**  
(right and left)



**AFCGX43B**  
(right and left)



**AFCEX43B**  
(right and left)

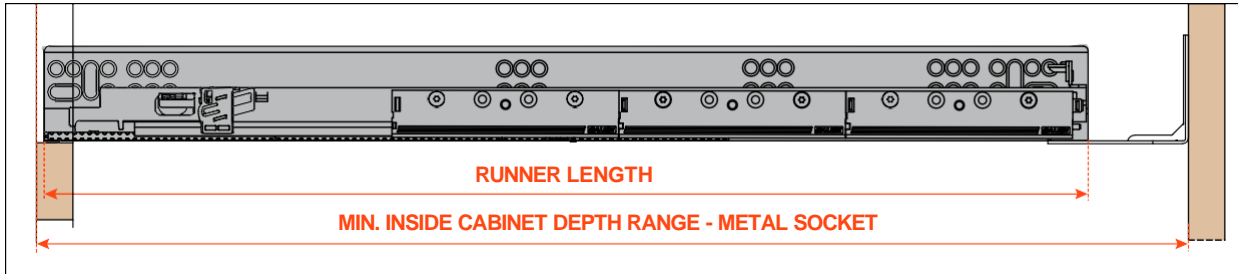

**AGSK7C5B**



**AGSK7R5B**



PART NUMBER	DRAWER LENGTH (LC)	RUNNER LENGTH (LN)	MINIMUM INSIDE CABINET DEPTH METAL SOCKET	MAXIMUM INSIDE CABINET DEPTH METAL SOCKET	MINIMUM INSIDE CABINET DEPTH
G7U6P381XXB	381 mm (15")	392 mm	402 mm	446 mm	401 mm
G7U6P457XXB	457 mm (18")	468 mm	480 mm	522 mm	477 mm
G7U6P533XXB	533 mm (21")	544 mm	557 mm	598 mm	554 mm



### 457C - 533C - 610C - 686C - 762C

Blocked out face frame cabinets or frameless

See page 7.

**AFCGX3B**  
(right and left)



**AFCGX43B**  
(right and left)



**AFCEX43B**  
(right and left)

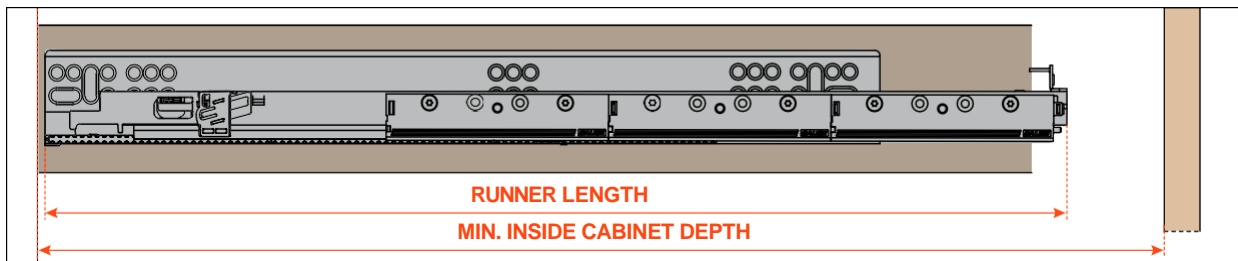

PART NUMBER	DRAWER LENGTH (LC)	RUNNER LENGTH (LN)	MINIMUM INSIDE CABINET DEPTH
G7U6P457CXB	457 mm (18")	468 mm	480 mm
G7U6P533CXB	533 mm (21")	544 mm	554 mm
G7U6P610CXB	610 mm (24")	621 mm	630 mm
G7U6P686CXB	686 mm (27")	697 mm	709 mm
G7U6P762CXB	762 mm (30")	773 mm	786 mm





# F70 Accessories

## F70 Push Synchronizer

The synchronization system for Push to Open F70 runners has been developed to ensure that drawers of any width can be opened with minimum effort.

The system links the two runners, which then become a single element; applying pressure on any part of the drawer front (even at the extremities), is sufficient for the Push devices to release and consequently for the drawer to open.

The synchronization can be used with any drawer width; its functionality is at its best with drawers wider than 762 mm (30").

### PRODUCT FEATURES:

- frameless or blocked out face frame applications
- smooth running action
- load capacity of the runner remains unchanged
- available on any F70 drawer length
- minimum opening (X) = 280 mm
- maximum opening (X) = 1305 mm
- bar length = 1150 cut to size



### Technical information - Formula for cutting the bar to length

The assembly of the synchronizer requires a minimum 76.2 mm (3") groove in the rear of the drawer.

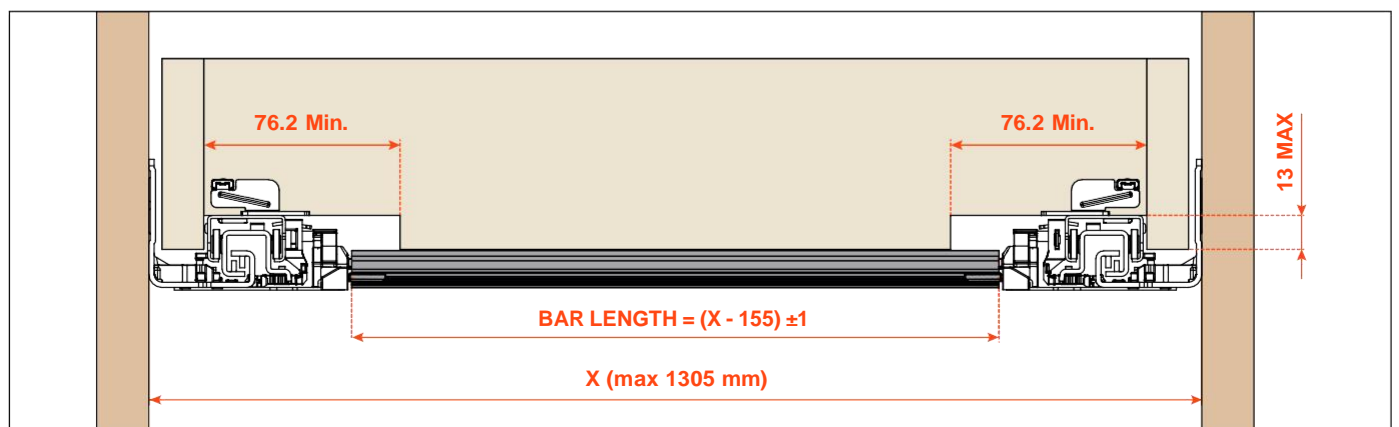

**X = Internal width of the cabinet**

## Assembly instructions

Slide the carrier plates into position on the runners in the direction indicated by the arrows

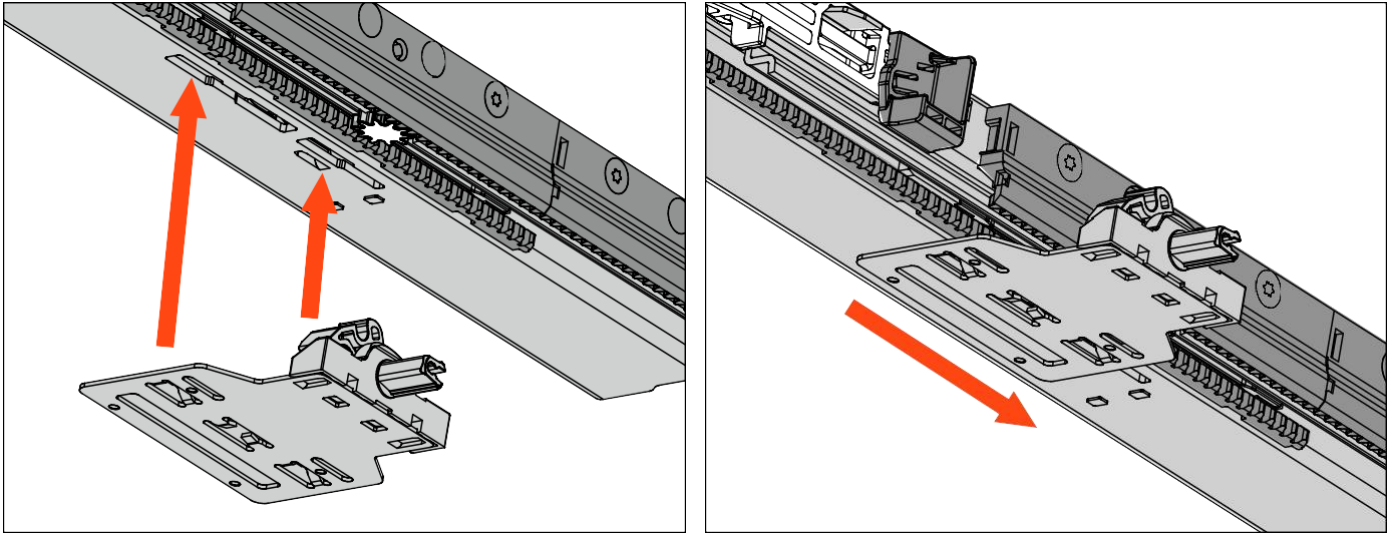

Fitting the driver pins to the runners

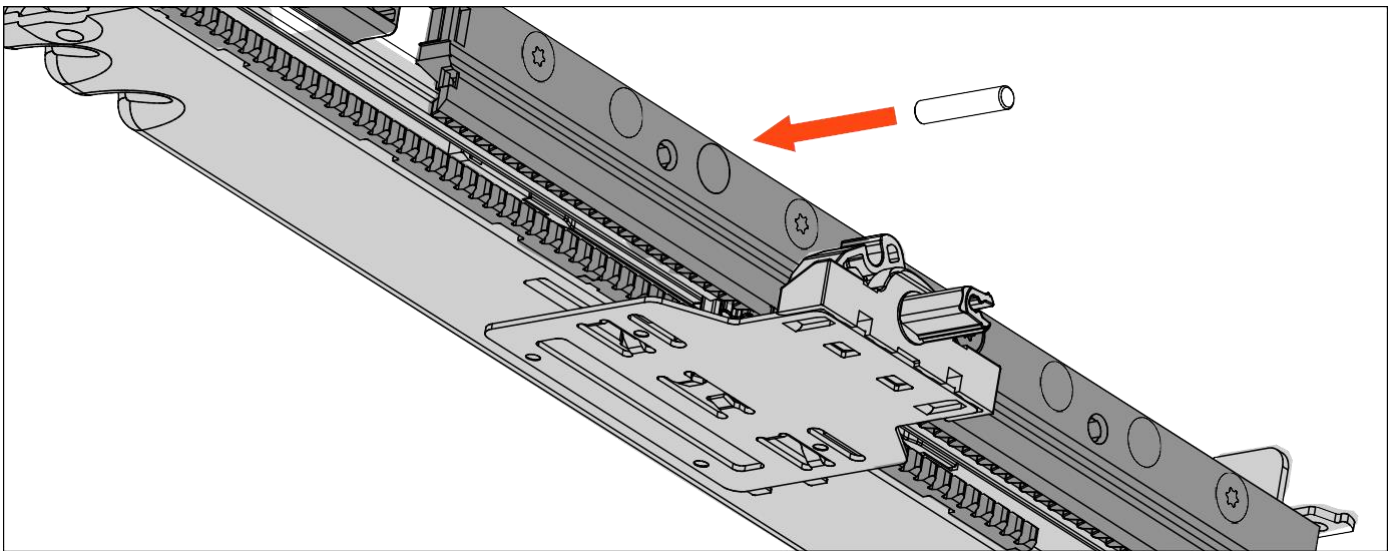

Cut the stabilizer bar to length

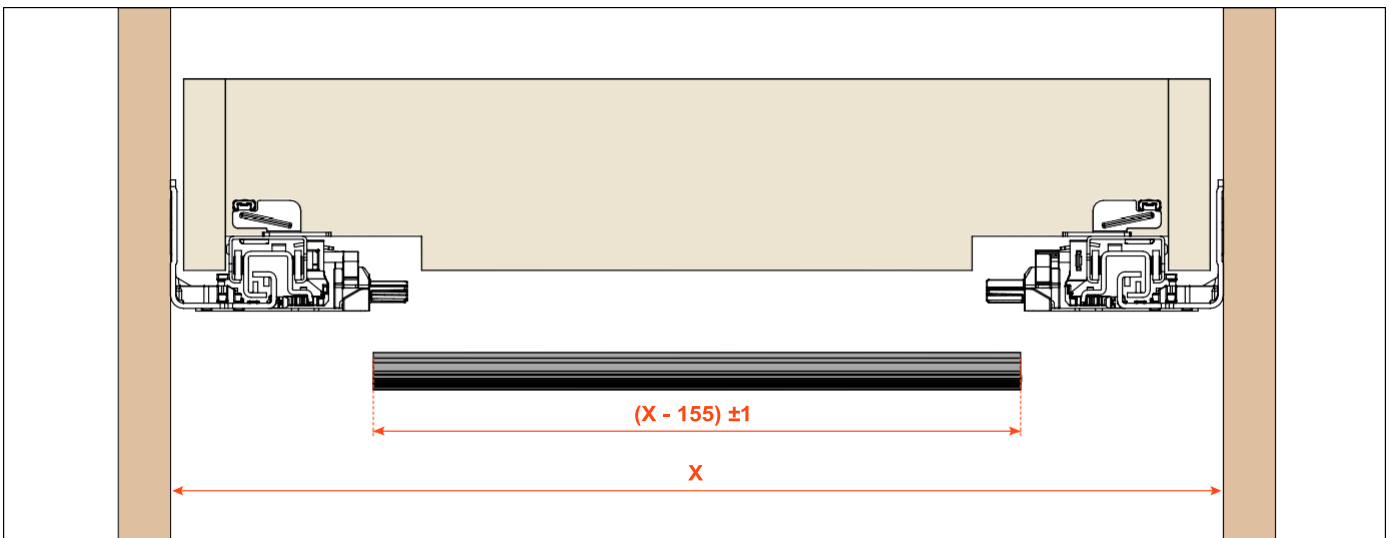



## Assembly instructions

Fix the bar to the plates and insert the drawer

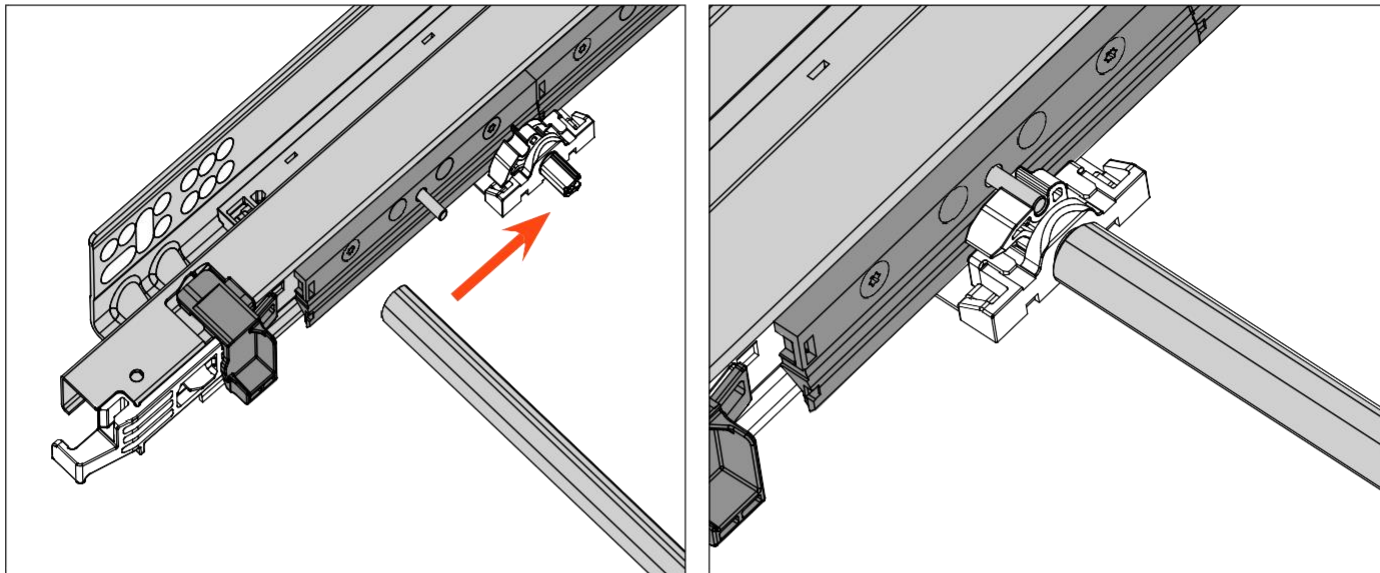

Applying pressure on any part of the drawer front is sufficient for the drawer to open

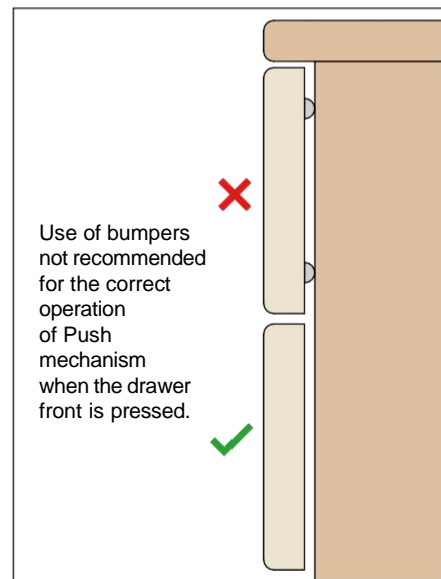

## Packaging

### SYNCHRONIZER - SINGLE KIT PACKAGING

**APKF7X51150**

PACKAGING

Box = 20 single kits

1 KIT CONTAINS:

- 1 stabilizer bar
- 2 driver pins
- 2 carrier plates



## Steel sockets

### Standard steel socket

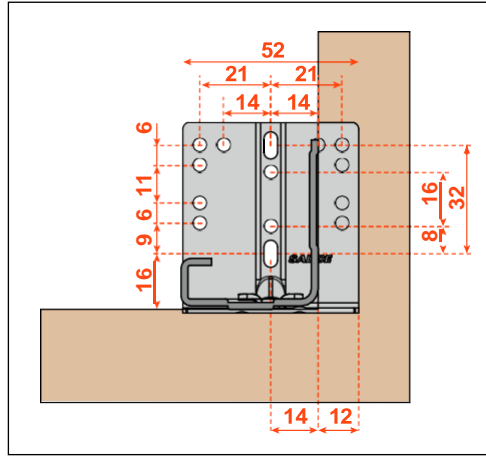
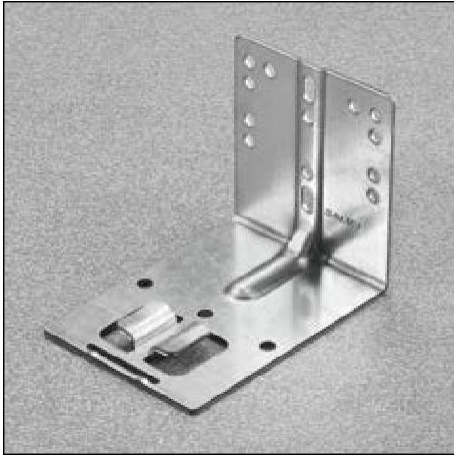

#### AGSK7C5B

PACKAGING  
1 box = 100 pcs.

- For F70 full extension runners
- Lateral self-alignment feature
- One piece stamped steel, zinc-coated
- Non-handed
- Use a minimum of 4 screws per socket

### Narrow steel socket

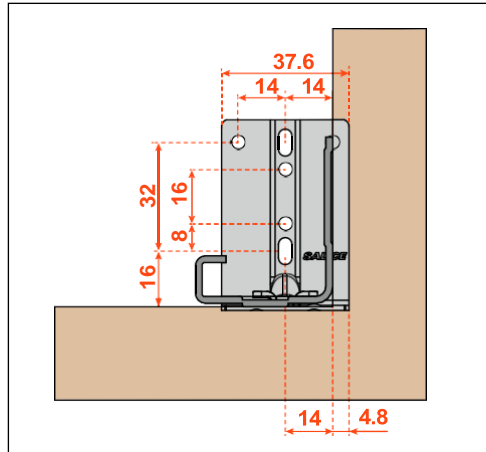
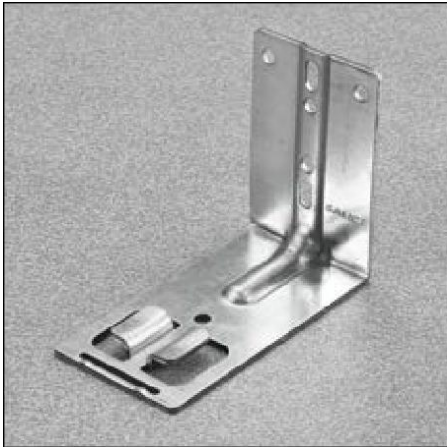

#### AGSK7R5B

PACKAGING  
1 box = 100 pcs.

- For F70 full extension runners
- Lateral self-alignment feature
- One piece stamped steel, zinc-coated
- Non-handed
- Use a minimum of 4 screws per socket

## Drilling templates for drawers

Pre-drilling for the clips reduces the possibility of splitting the wood, thus assuring the correct and level installation of the clips.

The correct and level mounting assures a smooth assembly and operation of the drawer slide.

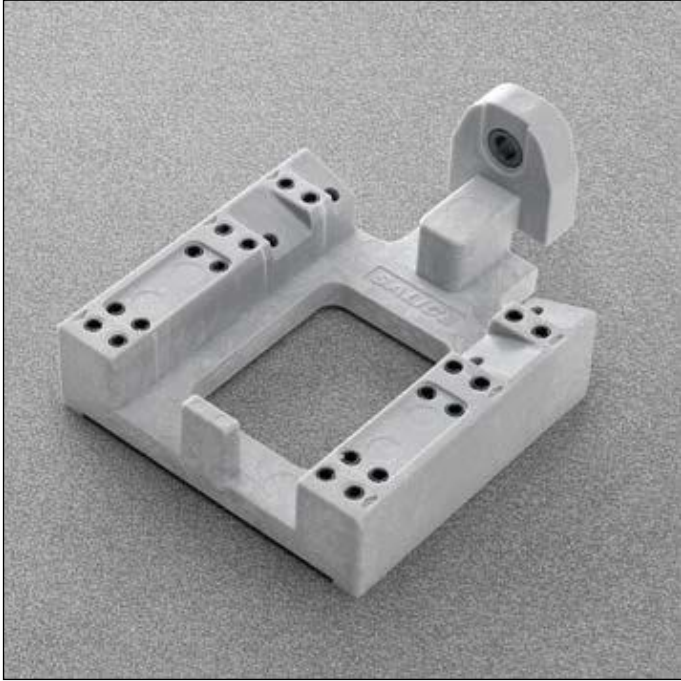

**SGD704UGXA**

PACKAGING  
1 box = 1 pc.

### Back drilling for hook

Pre-bore for rear hook for proper alignment and depth (min. depth = 10 mm or 13/32")



Use a  $\varnothing$  6 mm (1/4") drill bit



### Angled drilling for clips, fixing on the sub-front



Use a  $\varnothing$  2,5 mm (3/32") drill bit

### Vertical drilling for clips, fixing on the bottom



Use a  $\varnothing$  2,5 mm (3/32") drill bit

## Drilling templates for drawers

Vertical fixing under the sub-front



Use a  $\varnothing$  2,5 mm (3/32") drill bit

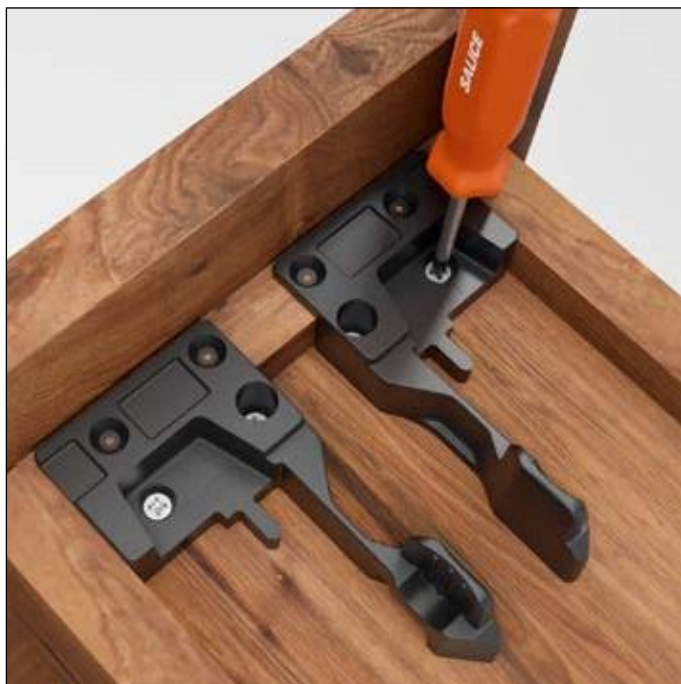

## Tilt adjustment lever

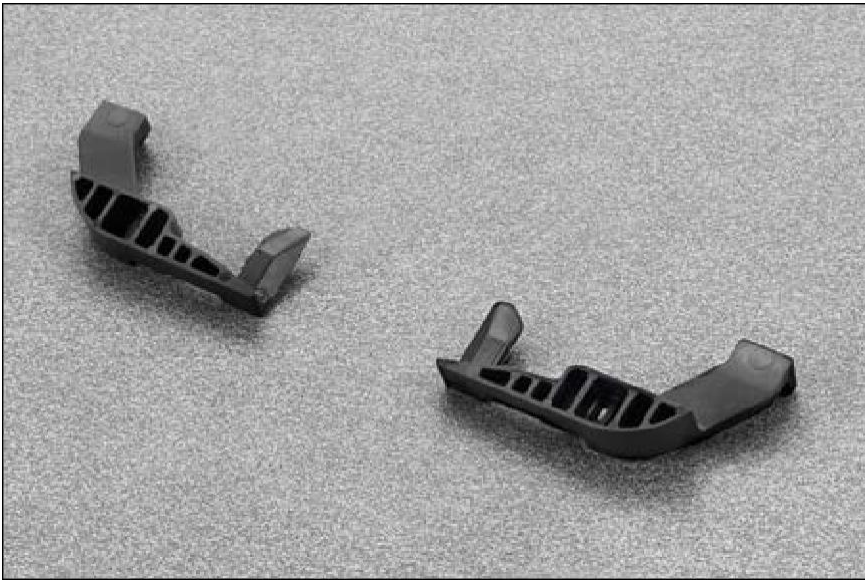

### AGLRXX3F

#### PACKAGING

1 box = 12 pcs. left, 12 pcs. right

Technical information, see page 19.

## Side spacer

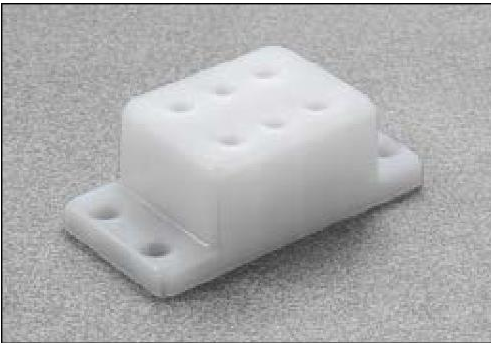

### ASPACERFUT

For spacing out F70 runners for clearance on interior roll-outs.

#### PACKAGING

1 box = 100 pcs.

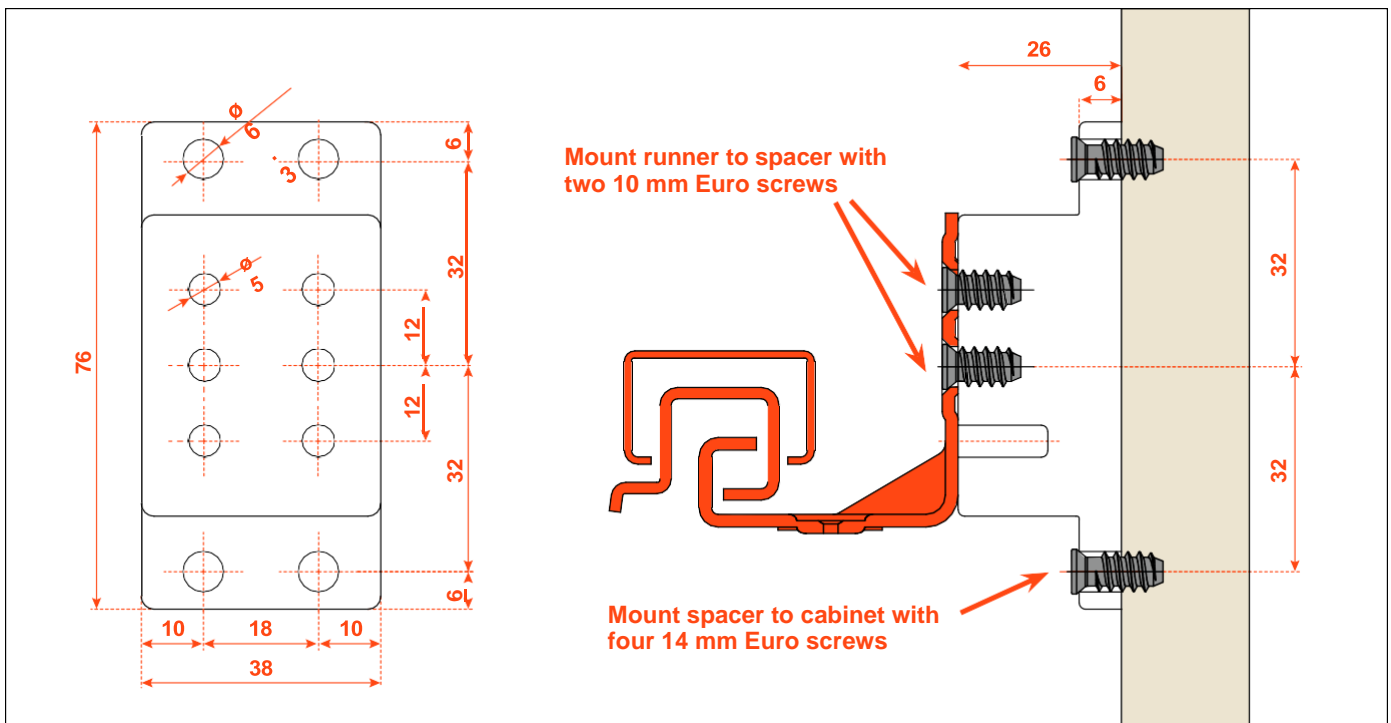



## Wood screw

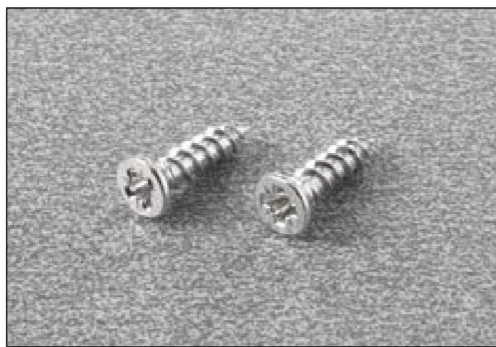

### V234X164

Wood screw # 6 x 5/8"

PACKAGING

1 box = 100 pcs.

## Euro screw

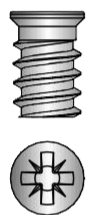

### V136X114

Euro screw # 6 x 11 mm

**In pollici come sopra**

PACKAGING

1 box = 100 pcs.

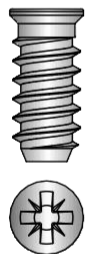

### V136X154

Euro screw # 6 x 14.5 mm

**In pollici come sopra**

PACKAGING

1 box = 100 pcs.

## Pozi driver

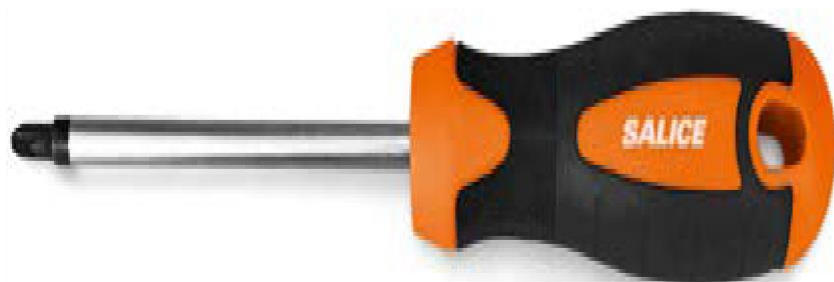

### D2A7XCXCP

PACKAGING

1 box = 100 pcs.



## **SALICE AMERICA INC.**

2123 CROWN CENTRE DRIVE  
CHARLOTTE NC. 28227  
TEL. 704 841 7810  
FAX. 704 841 7808  
info.salice@saliceamerica.com  
www.saliceamerica.com



**Digital contents**